

GERMAN  
POOL



德國寶

窗口式空調  
Air Conditioner  
Window Type

WAC-307R

WAC-312R

WAC-309R

WAC-318R

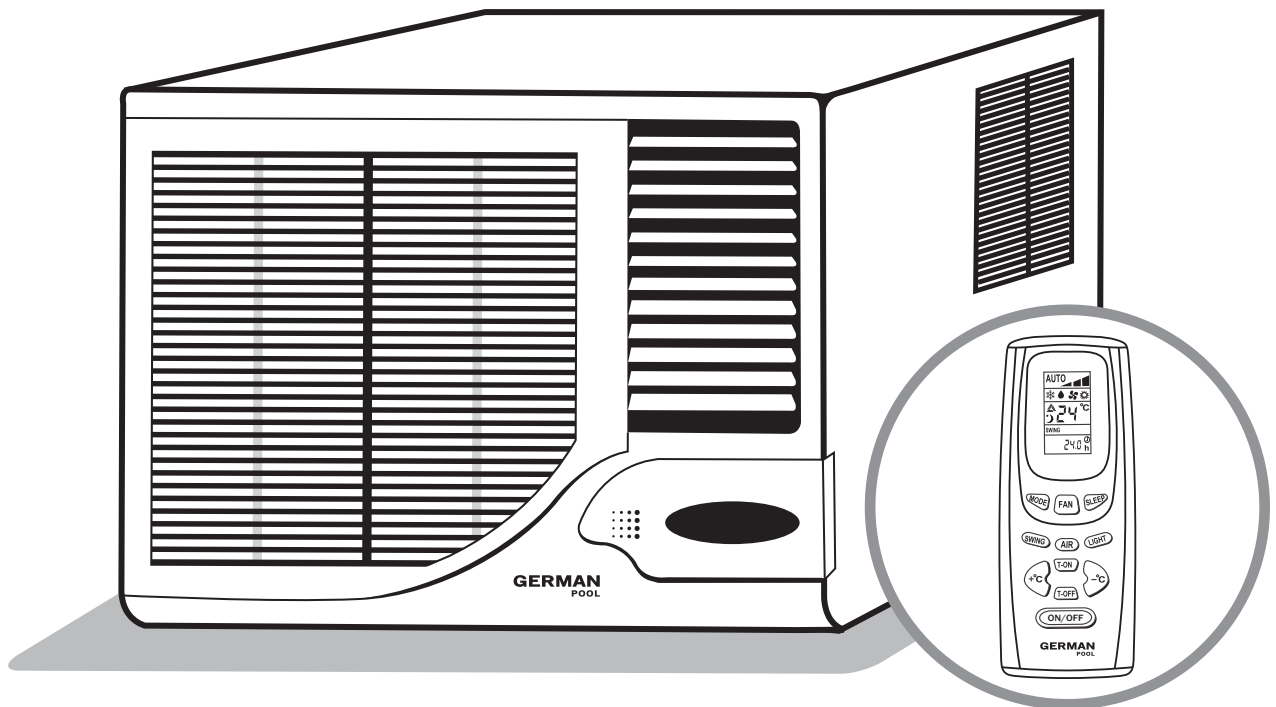

( 附遙控器 With Remote Control )

在使用之前請詳細閱讀「使用說明書」及「保用條例」，並妥為保存。

Please read these instructions and warranty information carefully before use and keep them handy for future reference.

使用說明書 OPERATING INSTRUCTIONS



# 目錄 TABLE OF CONTENTS

---

使用前須知 Before Use	02
供電要求 Power Requirement	02
產品結構 Product Structure	03
I. 主機 Main Body	
III. 操作面板 Control Panel	
III. 無線遙控器 Wireless Remote Control	
安裝 Installation	05
使用說明 Instructions	07
遙控器操作 Remote Control	08
I. 自動運轉模式 AUTO Mode	
II. 製冷模式 COOL Mode	
III. 除濕模式 DRY Mode	
IV. 睡眠狀態設定 SLEEP Settings	
V. 定時設定 TIMER Settings	
操作提示 Operating Notice	13
安全注意事項 Safety Caution	13
保養與維護 Care & Maintenance	14
常見問題及處理方法 Troubleshooting	15
技術規格 Technical Specifications	16

# 使用前須知 BEFORE USE



- 安裝工作必須由持牌技師進行  
Installation must be conducted by a licensed technician
- 不要安裝冷氣機在電視機或收音機附近，以免視頻或聲音受干擾  
Do not install unit near the TV set or radio in order to avoid disturbance of video or sound
- 如要安裝冷氣機在鹽田附近、沿海地區、溫泉地區或受含硫氣體污染的地方，請必先諮詢當地銷售商後才開啟使用  
In salt fields, coastal areas, thermal spring regions or places polluted by sulphurous gas, please consult your local seller before use
- 冷氣機切勿安裝在可能出現易燃氣體洩漏的地方  
Avoid places with possible flammable gas leakage
- 冷氣機切勿安裝在靠近熱源或陽光直接照射的地方  
Avoid places near heat sources or direct sunlight
- 避免安裝冷氣機在容易讓兒童接觸到的地方  
Avoid places where it is easy for children to touch

## 供電要求 POWER REQUIREMENT

### 額定功率 Rated Voltage

約 Approx. 220-240 V

當電壓過高，壓縮機會造成猛烈的顫動，從而破壞了製冷系統

If voltage is too high, the compressor would vibrate violently. It would damage the refrigerating system

### 電路 Electric Circuit

- 必須使用特別插座  
A special socket must be used
- 切勿使用較長的電源線  
Do not use longer power cords
- 切勿與其他電器共用同一插座，以避免引起意外  
Do not share a same socket with other electric appliances to avoid causing a fire
- 電路必須可靠接地  
Circuit must be reliably grounded
- 必須在額定功率範圍下操作  
Operate unit within correct voltage range

### 連接地線 Earth Wire

切勿在以下地方接地：

Do not connect earth wire to following places:

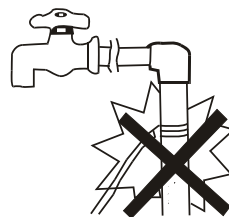

水管 Water Pipe

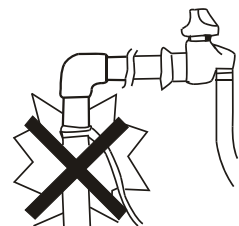

氣喉 Gas Pipe

# 產品結構 PRODUCT STRUCTURE

## I. 主機 Main body

外箱 Casing

空氣出口柵格 Air Outlet Louver

空氣過濾網 Air Filter

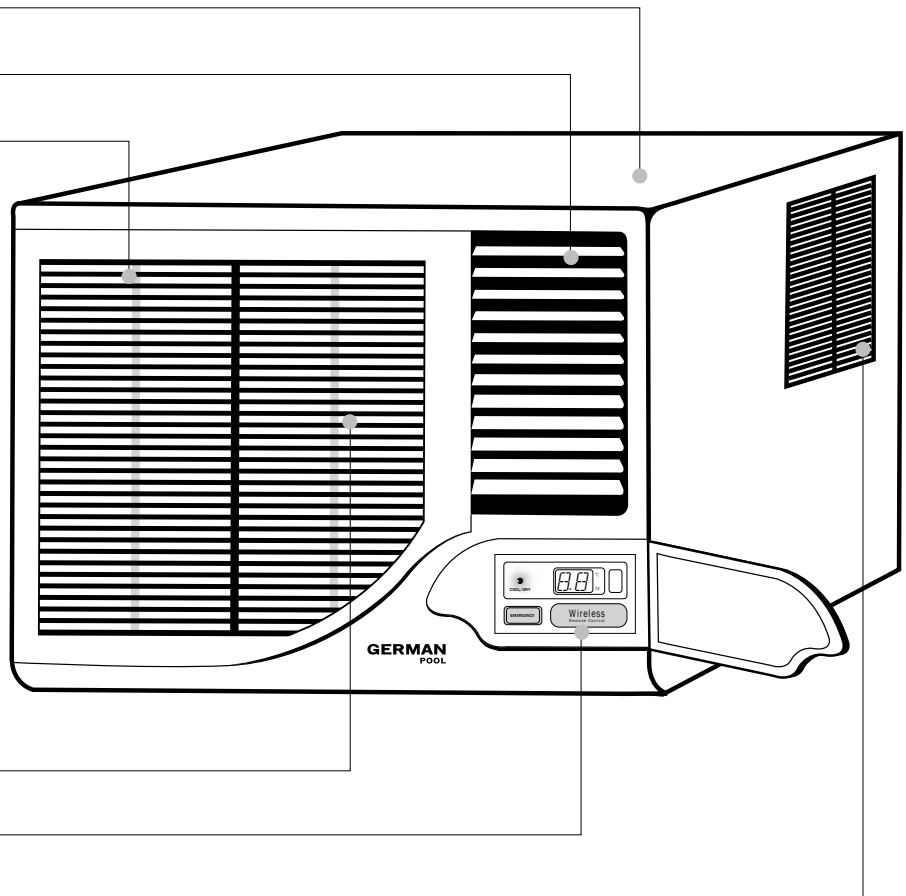

空氣入口柵格 Air Intake Grille

操作面板 Control Panel

空氣入口百葉 Air Vent

## II. 操作面板 Control Panel

遙控訊號接收器 Remote Control Signal Receiver

溫度及時間顯示 Temp/Time Display



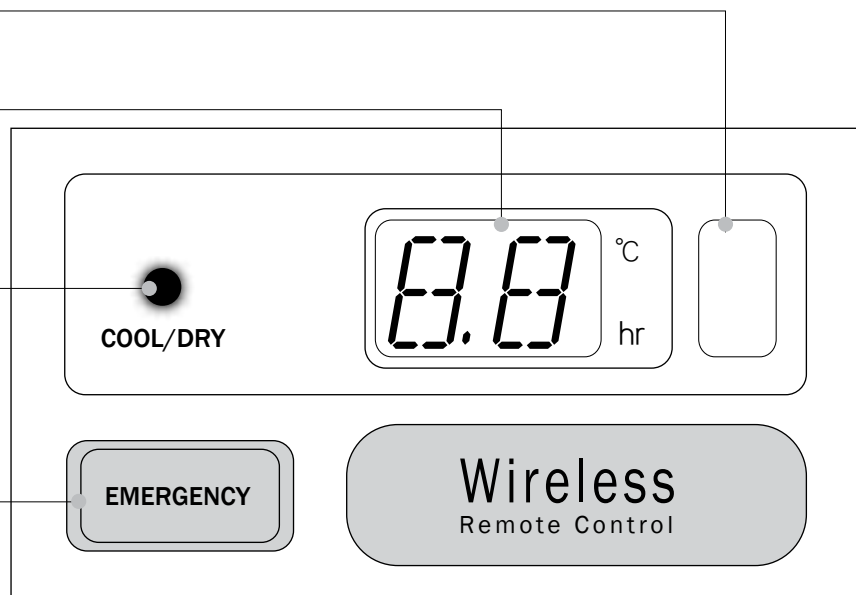

[ 運作中 ] 指示燈 COOLING Indicator

手動開關按鍵  
Manual On/Off Button



# 產品結構 PRODUCT STRUCTURE

## III. 無線遙控器 Wireless Remote Control

 自動狀態 AUTO Mode  
 製冷狀態 COOL Mode  
 抽濕狀態 DRY Mode  
 送風狀態 FAN Mode  
 製熱狀態 (只適用於冷暖型)  
 HEAT Mode (Dual Type models only)

**MODE 鍵 (模式選擇) MODE Button**

逐次按 MODE 鍵，運行方式按下述依次變化：  
Press this button to select mode in following order:



**FAN 鍵 (風速) FAN Button**

每按一次鍵，風速按下述依次變化：  
Press to change fan speed in the following order:



**SWING 鍵 (搖擺送風) SWING Button**

按一次導風板會自動按一定的角度進行左右掃風，再按一次則停止動作  
When pressed, the louvers start to swing left and right automatically; louvers stop when re-pressed

**T-OFF 鍵 (定時關機) T-OFF Button**

在開機狀態下可設定定時關機時間，每按一次鍵，定時關時間上升0.5小時。按下述方式循環：  
During operation, press this button to set switch off time (max. 24 hours). Increase 0.5 hour by each press:

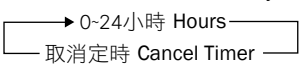
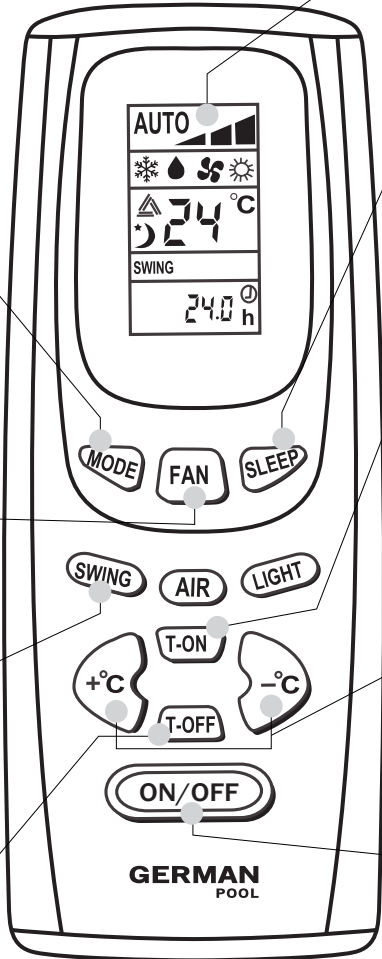
**液晶顯示器 Display Screen**

顯示各按鍵所選擇的信息  
Displays message and unit status

**SLEEP 鍵 (睡眠狀態) SLEEP Button**

按一次為睡眠狀態，再按一次退出睡眠狀態  
Press to switch on or off SLEEP mode

**T-ON 鍵 (定時開機) T-ON Button**

在關機狀態下，可設定定時開機時間，每按一次鍵，定時開時間上升 0.5 小時。按下述方式循環：  
When operation is off, press this button to set switch on time (max. 24 hours). Increase 0.5 hour by each press:

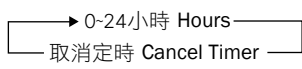

**TEMP 鍵 ( +°C 及 -°C 溫度設定) TEMP Buttons ( +°C & -°C )**

每按一次 +°C 設定溫度上升一度，按一次 -°C 設定溫度下降一度。  
在 ❄️, 💧, 🌬️ 模式下，室溫在 16°C ~ 30°C 間任意調整  
SET TEMP increases by 1°C when +°C button is pressed once and decreases by 1°C when -°C button is pressed.  
In ❄️, 💧, 🌬️ modes, SET TEMP. can be adjusted between 16°C and 30°C

**ON/OFF 鍵 (開關) ON/OFF Button**

按此按鍵，冷氣機便開始運轉，再按一次，冷氣機便停止運轉  
Press to turn on or shut down the unit



### 注意 Caution!

- 確保遙控器與信號接收窗之間無障礙物  
Make sure there is no obstruction between remote control and signal receiver on the unit
- 遙控器信號的接收距離可達10米左右  
Remote control signals can be transmitted within 10 m distance
- 切勿讓遙控器於高處掉落或將其隨意扔擲  
Do not drop or throw remote control
- 切勿使任何液體流入遙控器內、受陽光直射或置於極熱處  
Keep remote control away from any liquid, direct sunlight or heat sources

# 安裝 INSTALLATION



## 安裝前注意 Notice

- 冷氣機周圍不應有任何障礙物阻擋機身，以免影響散熱  
There should not be any obstacles surrounding the unit
- 安裝開孔必須稍大於冷氣機機身尺寸  
Installation cutout hole must be slightly bigger than the unit size

## 安裝程序 Installation Procedure

### ① 提出空氣過濾網 Remove air filter

### ② 拆下前面板 Remove front panel

- 去除前面板頂部和底部的黏貼膠帶  
Remove the adhesive tape from the top and bottom of the front panel
- 將格柵向上拉出，使頂部兩邊的固定扣從插槽鬆開  
Slide the grille upward to free the two tabs at the top of the grille from slots at the top of the cabinet

### ③ 準備底盤 Prepare chassis

- 鬆開機箱兩邊的鎖扣螺絲  
Remove both chassis locking brackets by loosening the screws
- 將底盤取出  
Slide the chassis out from the cabinet

### ④ 裝好機箱 Place cabinet into opening

- 安裝時，機箱後方應略為向下傾斜，方便排走冷凝水（約6-10毫米差距）  
The cabinet should be installed tilted slightly lower to the rear for condensation drainage. (Range: 6~10mm)
- 安裝應選擇一個能夠支撐機身重量、同時不會導致額外噪音和震動的位置  
Select a location that can support the weight of unit body and one that will not cause extra noise and vibration during operation

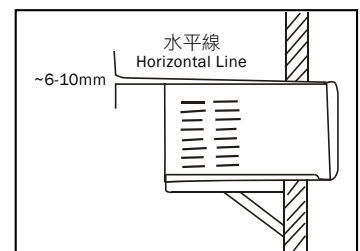

### ⑤ 將底盤置入機箱 Slide chassis into the cabinet

- 不應有任何喉管觸碰到機箱  
Tubing or ducting part should not have contact with the cabinet
- 將底盤以兩邊的鎖扣鎖好於機箱  
Lock the chassis into cabinet by chassis locking brackets

### ⑥ 利用螺絲將格柵裝於機箱 Affix front grille onto cabinet with a screw

- 將格柵的頂部與機箱頂部扣好，然後按入格柵的底部直至到位，最後用螺絲鎖好  
Hook top of grille onto top of cabinet. Then push and snap bottom of grille into place. Secure front grille with the screw

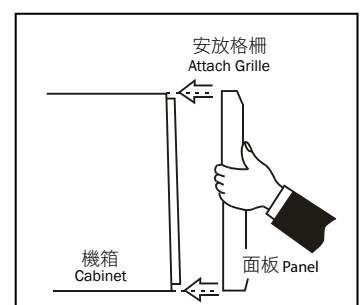

# 安裝 INSTALLATION

## 輔助配件 (另購) Installation Accessories (Optional)

### 金屬支架 Metal Support

- 安裝位置必須足以支持冷氣機身，否則應額外安裝一個金屬支架以作承托  
Installation cutout should be strong enough to support the air conditioner. Otherwise, a metal support has to be used
- 金屬支架必須裝建在建築物外牆  
Iron support should be fixed on the building

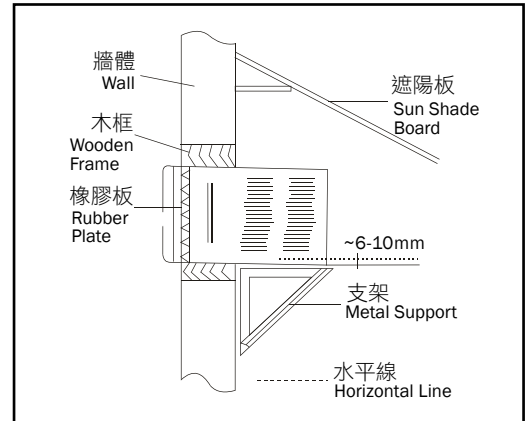

### 太陽遮擋 Sunlight Shield

- 冷氣機身應避免受陽光直接照射或有異物跌落。若機身對上沒有蓋的話，應聯絡銷售商為閣下安裝一個太陽遮擋  
Avoid direct sunlight and anything to be dropped onto unit. If there is no cover on it, you should contact the seller for installation of a sunlight shield
- 陽光遮擋和支架可直接從銷售商購買，以配合閣下的特別需要  
Sunlight shield and support can be purchased from your local supplier to accommodate your special needs

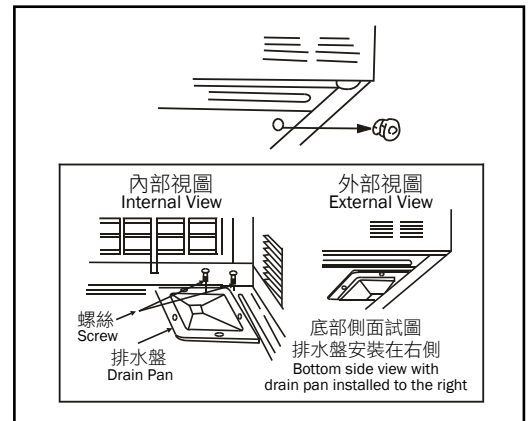



# 使用說明 INSTRUCTIONS

## I. 風向控制 (縱向) Air Direction Adjustment (Vertical)

利用垂直的風向控制桿可調整氣流向上、向下或水平方向送出。  
The vertical airflow lever is controlled by positioning the lever to direct the air upwards, downwards or straight out.

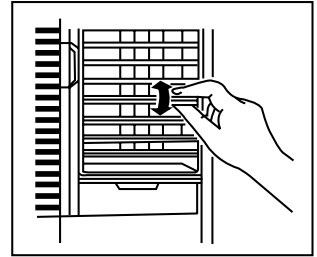

## II. 鮮風控制 Ventilation Lever

將調整桿設定在：  
Set the slide lever at the following positions:

### OPEN (開啟)

- 通風門打開，讓鮮風流入，並將室內空氣、煙霧或氣味等排出房外  
Vent opens to allow fresh air to enter and let indoor air, smoke or odour to be expelled from the room



### CLOSE (關閉)

- 通風門關閉，房間內空氣自行循環和受到調節  
Vent door is closed and indoor air is circulated and conditioned within the room

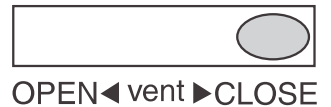

## III. 遙控器電池 Remote Control Battery Change

- 請勿把新舊電池或類型不同的電池混用  
Do not mix new and worn batteries together. Do not use different types of batteries at the same time
- 若長時期不使用遙控器，請將電池取出，防止漏液損壞遙控器  
Remove batteries from remote control if it is not to be used for an extended period
- 電池壽命約為一年  
Batteries will normally last for about 1 year

① 向下滑動遙控器後蓋。  
Remove the cover from the back of remote control.

② 放入2枚乾電池 (AAA乾電池)。  
Insert 2 batteries (AAA dry-cell).

③ 關上遙控器後蓋。  
Re-attach cover.

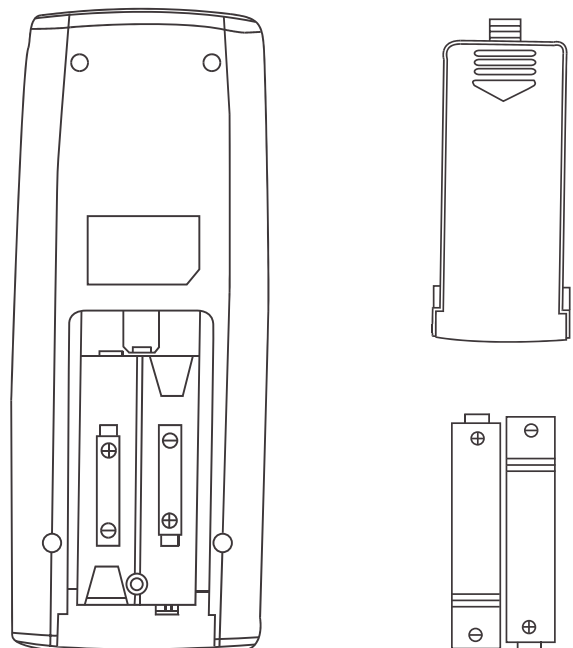

# 遙控器操作 REMOTE CONTROL

## I. 自動運轉模式 AUTO Mode

- 在自動模式下，標準製冷設定溫度為 25°C，風速可更改  
In AUTO mode, standard SET TEMP. is 25 °C and fan speed is adjustable
- 當室溫在 23°C 至 26°C 之間，冷氣機會自動設在風扇模式運轉  
If room temperature is between 23 °C to 26 °C, air conditioner automatically operates under FAN mode
- 當室溫在 26°C 以上，冷氣機會自動啟動製冷模式  
If room temperature is higher than 26 °C, it automatically switches to COOL mode

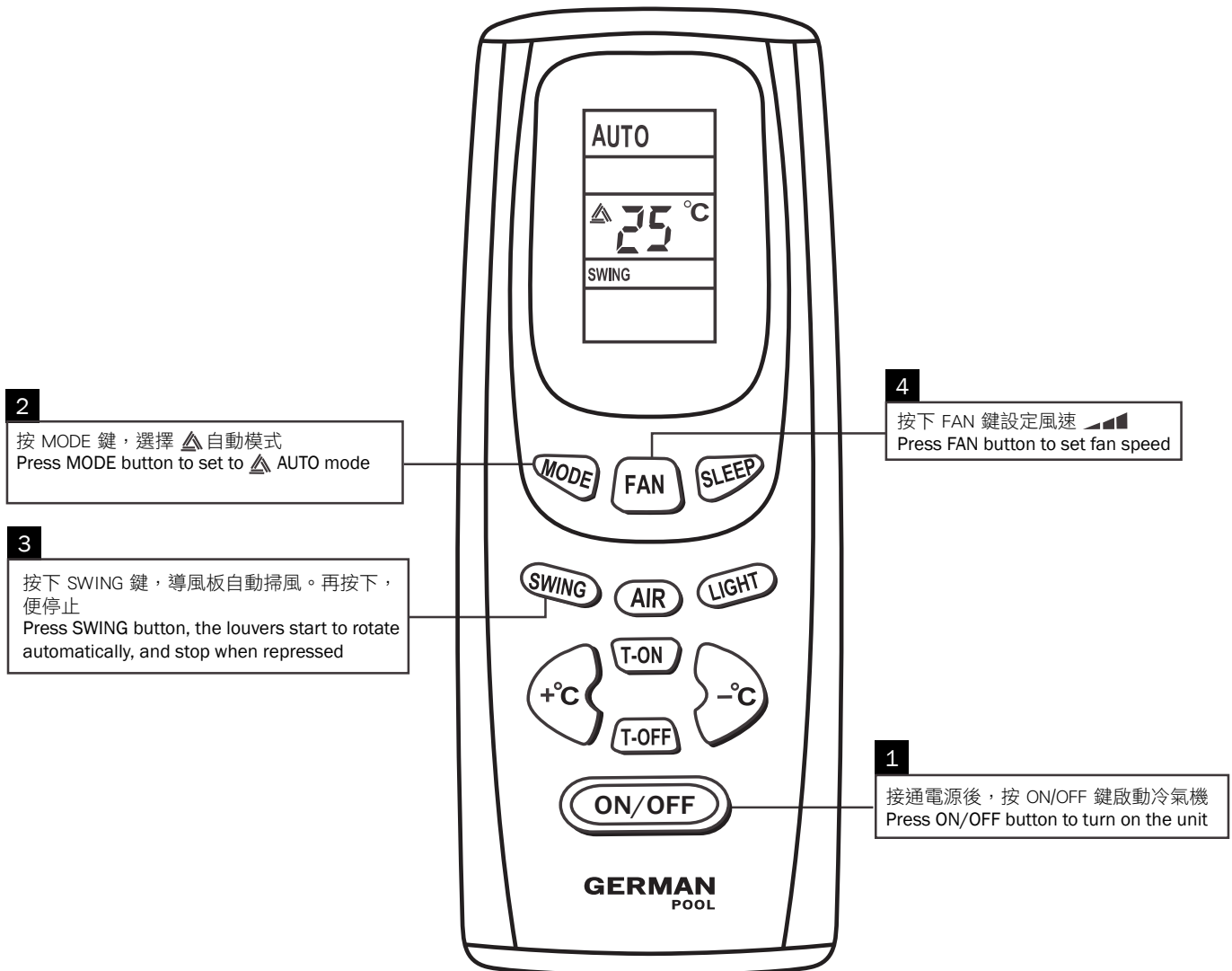

# 遙控器操作 REMOTE CONTROL

## II. ❄️ 製冷模式 COOL Mode

- 微電腦根據室溫傳感器感受的溫度和設定溫度之差，確定製冷模式開啟與否  
According to the difference between room temperature and set temperature, microcomputer would determine whether to operate in COOL mode or not
- 溫度設定範圍為16°C ~ 30°C  
Temperature should be set in the range from 16°C to 30°C

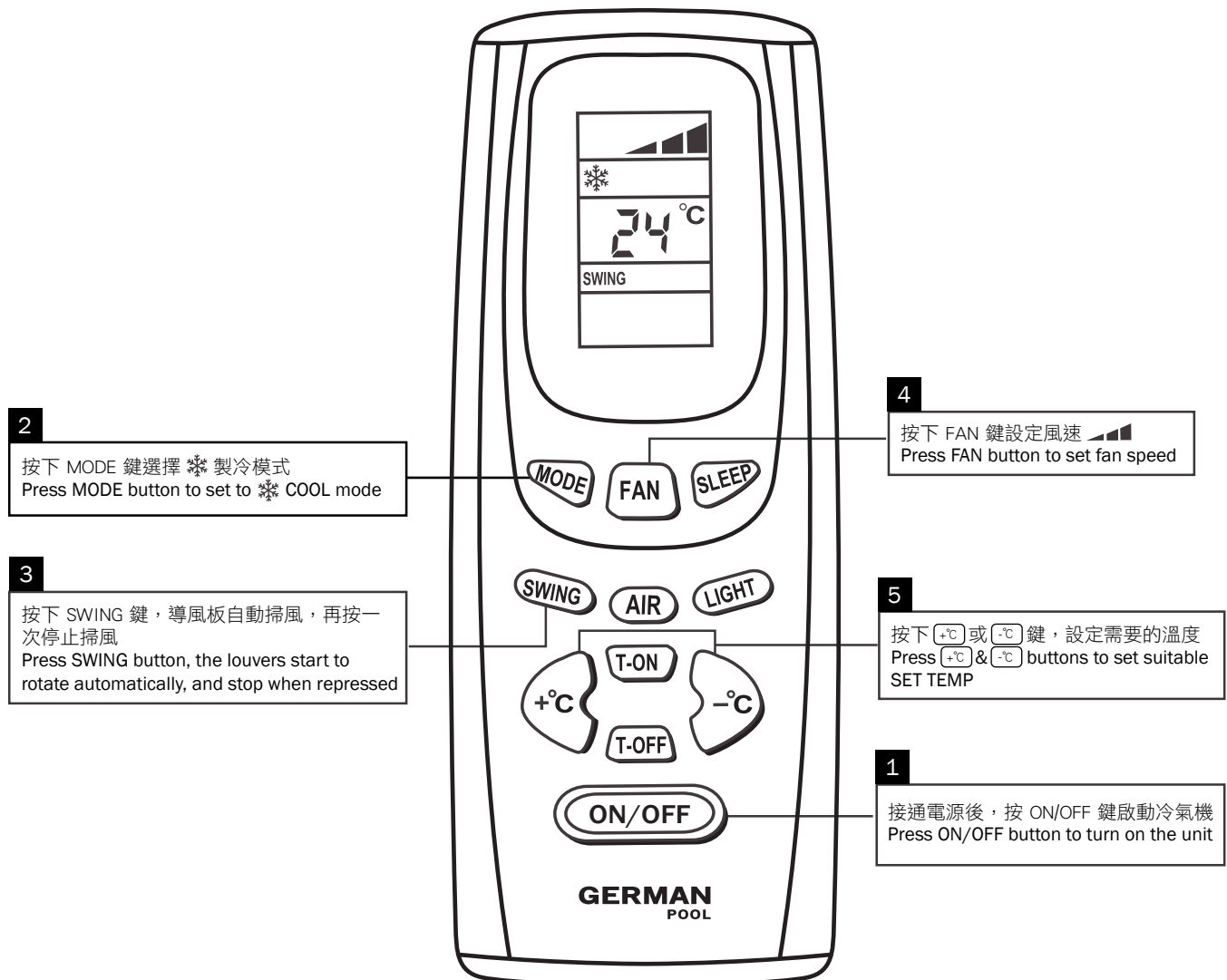

# 遙控器操作 REMOTE CONTROL

## III. 除濕模式 DRY Mode

- 微電腦根據室溫傳感器感受的溫度和設定溫度之差，確定抽濕模式啟動與否  
If room temperature is lower than SET TEMP., compressor and fan motor stop. If room temperature is within  $\pm 2^{\circ}\text{C}$  of SET TEMP., air conditioner is in DRY mode. If room temperature is  $2^{\circ}\text{C}$  or more higher than SET TEMP., it's at COOL mode
- 在此模式下，設定溫度範圍為 $16^{\circ}\text{C}$  ~  $30^{\circ}\text{C}$   
Temperature should be set in the range from  $16^{\circ}\text{C}$  to  $30^{\circ}\text{C}$

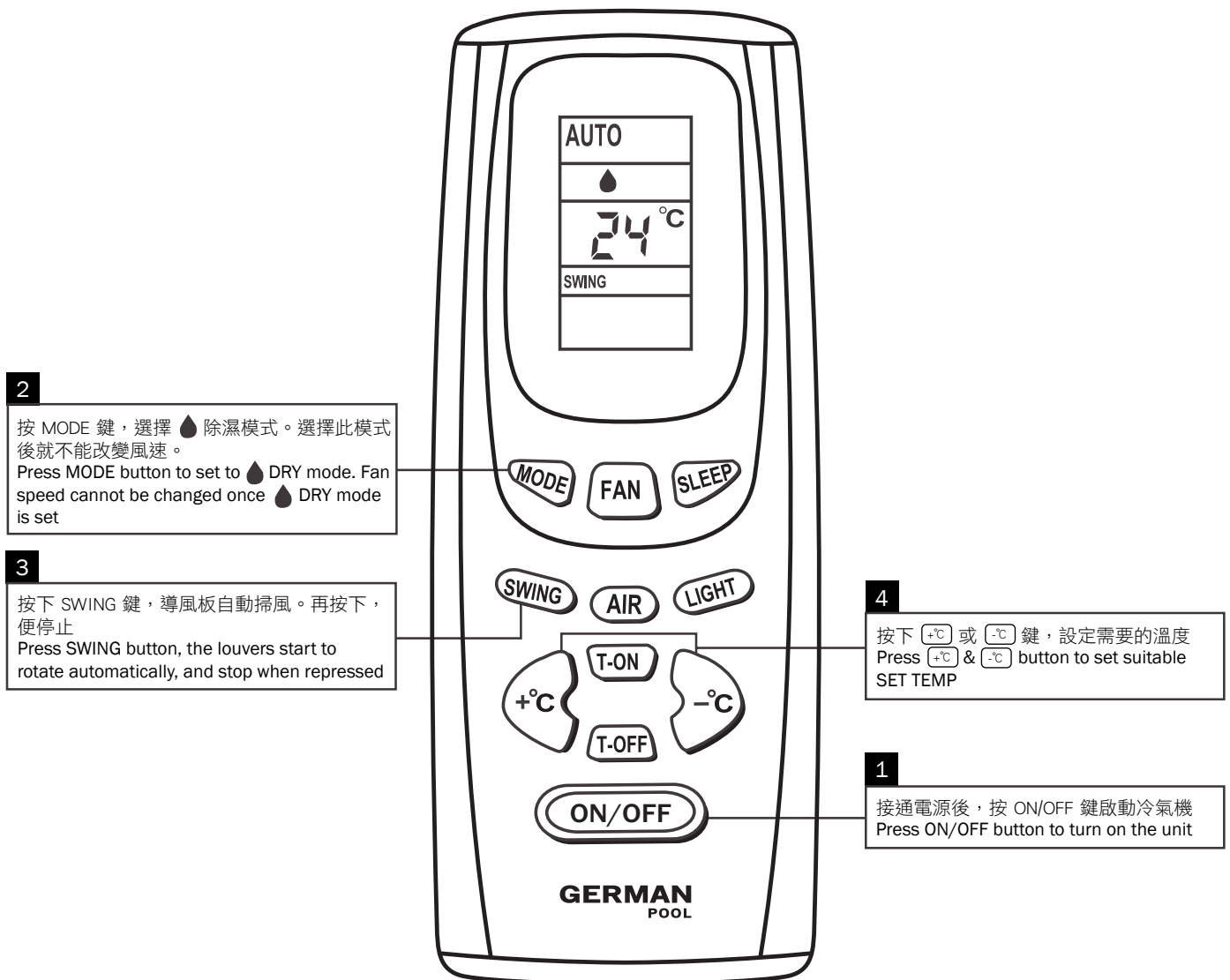

# 遙控器操作 REMOTE CONTROL

## IV. ☾ 睡眠狀態設定 SLEEP Settings

- 製冷和抽濕時，設定睡眠模式1小時後，設定溫度會升高1°C；2小時後，設定溫度會升高2°C  
While unit is cooling or dehumidifying, set to SLEEP mode and temperature would increase by 1 °C in 1 hour and 2 °C in 2 hours

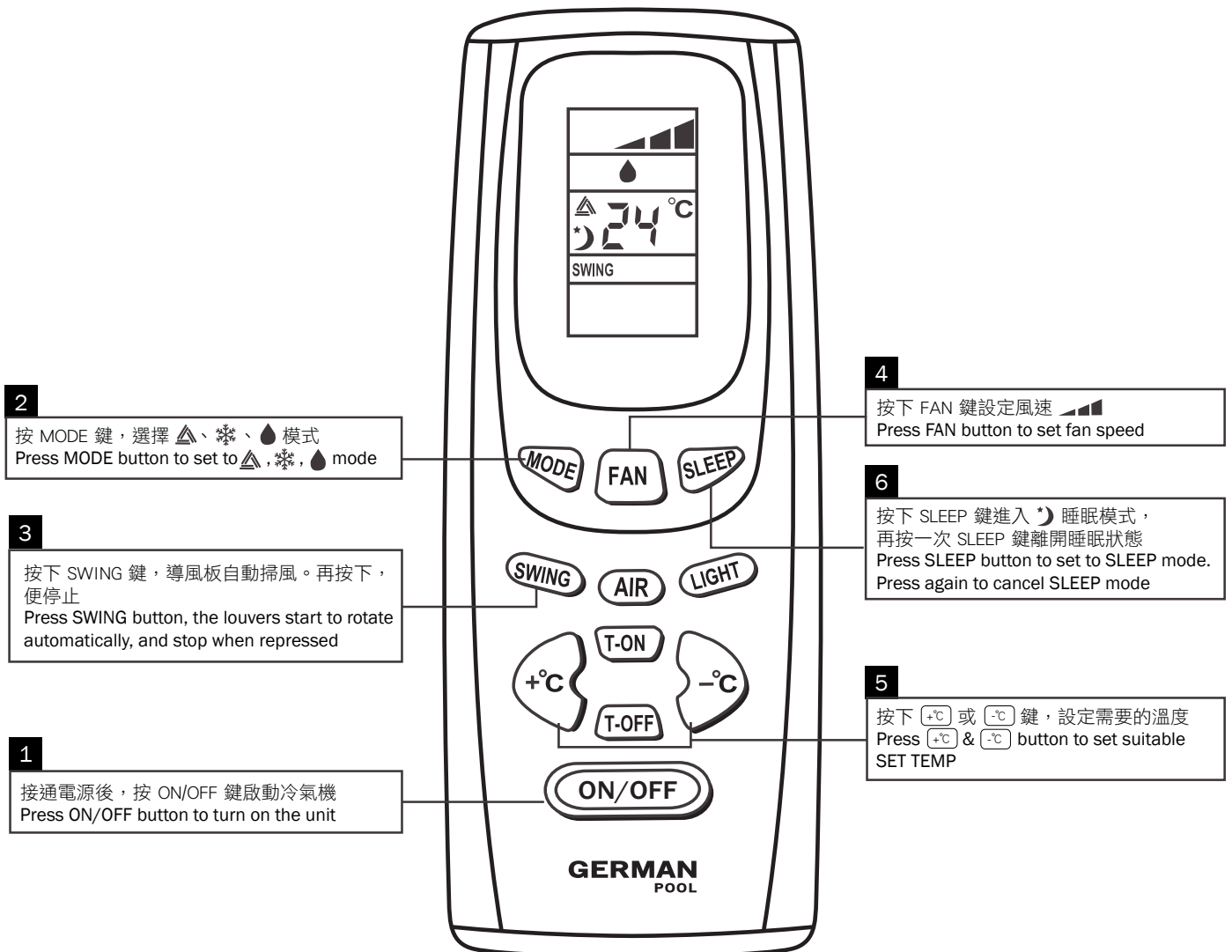

# 遙控器操作 REMOTE CONTROL

## V. ① 定時設定 TIMER Settings

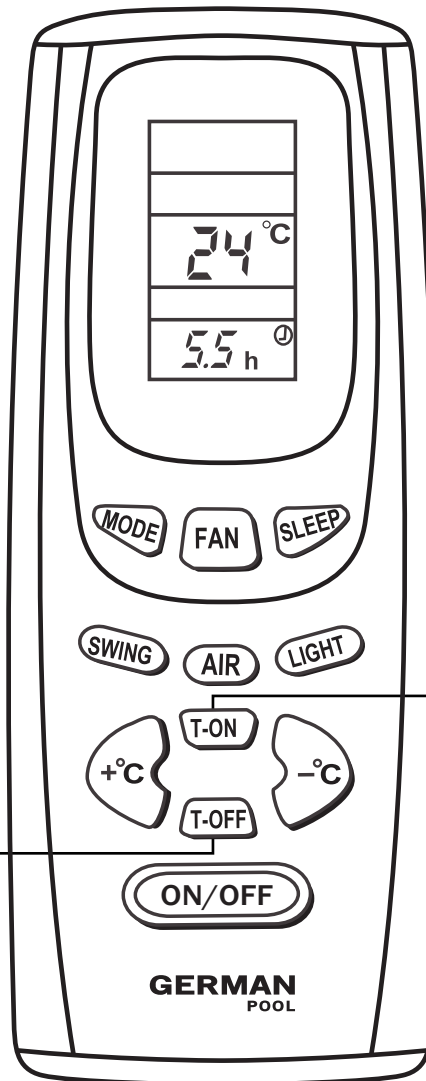

### T-OFF 鍵 (定時關機) T-OFF Button

在開機狀態下，可設定定時關機時間，每按一次鍵，定時關時間上升0.5小時。按下述方式循環：

During operation, press this button to set switch off time (max. 24 hours). Increase 0.5 hour by each press:

→ 0-24小時 Hours  
取消定時 Cancel Timer

### T-ON 鍵 (定時開機) T-ON Button

在關機狀態下，可設定定時開機時間，每按一次鍵，定時開時間上升0.5小時。按下述方式循環：

When operation is off, press this button to set switch on time (max. 24 hours). Increase 0.5 hour by each press:

→ 0-24小時 Hours  
取消定時 Cancel Timer

## 操作提示 OPERATING NOTICE

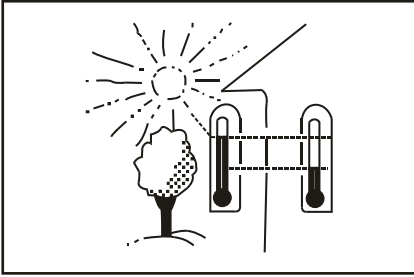

房內溫度請勿過冷，這樣不但對健康無益，且造成電源浪費。

Select the most appropriate temperature. It is not good to health and wastes electricity to overcool the room.

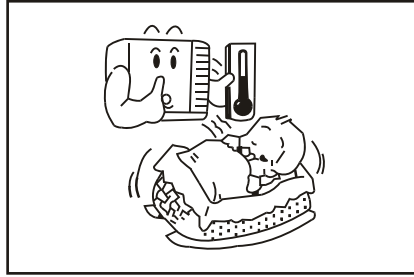

如房內有嬰兒、老人或病人，請調節適當的溫度。

If an infant or elderly is present in the room, adjust temperature to appropriate level.

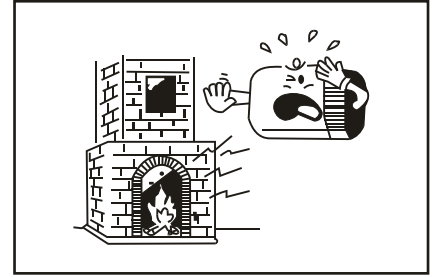

請勿在冷氣機的附近使用加熱設備。如有過多熱量散發，冷氣機的塑膠部件或會變形。

Do not use heating apparatuses in the vicinity. The unit's plastic parts may deform if exposed to excessive heat.

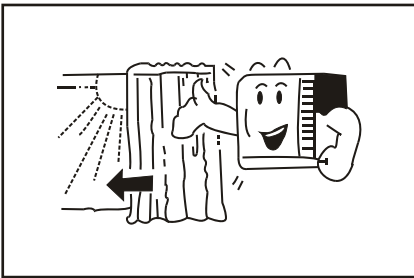

在冷氣機操作過程中，勿讓陽光直射進室內，請使用百葉窗及窗簾。

During operation, do not let sunshine enter the room directly. Keep blinds or curtains closed when air condition is in operation.

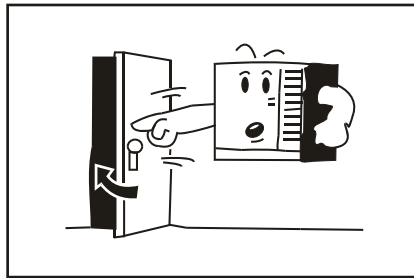

當冷氣機正在運作時，為了防止冷氣從房內流出，請關緊門窗。

Make sure doors and windows are shut tightly in order to keep cool air in the room.

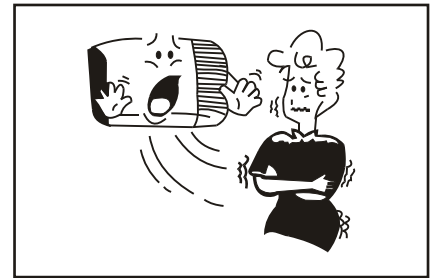

避免讓身體長時間對著冷氣機的出風口，這有礙身體健康。

For health reason, avoid exposing your body directly to the air flow from the unit for long period of time.

## 安全注意事項 SAFETY CAUTION

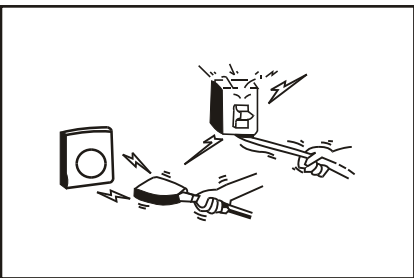

切勿強行拉出電源線。

Do not pull out the power cord. Damage to the cord may result in serious electrical shocks.

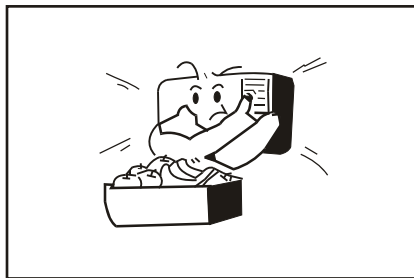

除了房間製冷作用外，請勿將冷氣機用作其它用途，如衣物烘乾、食物保鮮或蔬菜栽培。

Do not use the air conditioner for other purpose such as drying clothes, preserving foods or cultivating vegetables.

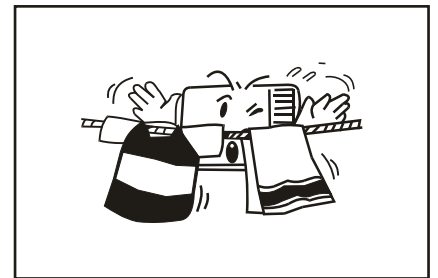

請勿阻擋冷氣機的進出風口，以免影響性能或不正常運作。

Do not block the air intake and outlet vents. This would affect performance and cause irregular operation.

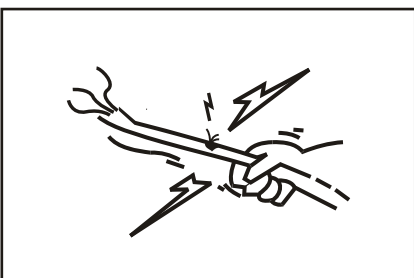

破損的電源線可能引發重大觸電事故。Damaged power cord must be replaced immediately.



冷氣機停止運作後，至少需要等待3分鐘才可重新開機。

Always wait at least 3 minutes before switching the unit on again after shutdown.

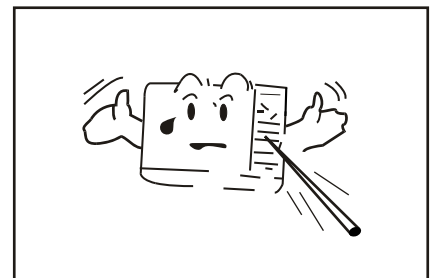

請勿將木棒類和其它細小物體插入進出風口以觸摸電器原件或風扇摩打，以免引致危險。

Do not insert any small or stick-form objects into the vents. Any contact with internal components are very dangerous.

# 保養與維護 CARE & MAINTENANCE

## 清潔機身 Cleaning Unit Body

在清潔之前首先拔下插頭。  
Unplug before cleaning.

只有在冷氣機完全關閉之後才可拔下插頭。  
Unplug only after air conditioner stops completely

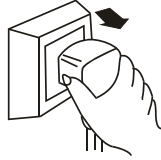

使用柔軟的乾布清潔表面面板，可浸泡在40°C下的溫水中。  
Clean surface panel with a soft and dampened cloth.



在清潔之前必須用手擰乾抹布。  
Soak dry cloth with warm water below 40°C

清潔時不得使用化學溶劑。  
Do not use any chemical solvent for cleaning.



不要將水直接潑在室內機體上。因為這裡安裝了微電腦以及電路板，不得碰水。

Do not splash water directly to the unit. Avoid contacts between water and the internal microcomputer or circuit board.



## 檢查地線 Grounding

地線不可損壞或鬆動。

Check earth wire.

Make sure it is securely fitted and not broken.

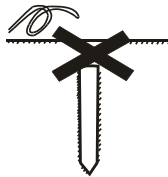

## 清潔過濾網 Cleaning Air Filter

進口格柵後部的防塵過濾網每兩周至少清洗一次，或者根據需要經常清潔。

Air filter behind the inlet grille should be washed at least every 2 weeks or as often as it needs.

向左推開面板，按住過濾網上掛鉤然後提起，取出過濾網。  
To remove the air filter, pull the grille to the left and lift the filter.

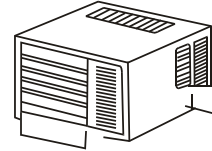

使用真空吸塵機吸去過濾網上的灰塵。  
Vacuum the filter on the dusty side to remove light dust.

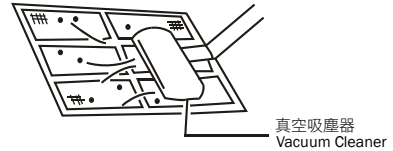

在流水中滴入少量清潔劑清洗過濾網上吸附的灰塵。  
Wash filter, cleaner side up, under gently flowing water to wash out accumulated dust and lint.



如果過濾網十分髒，可以在水中用少許中性家用清潔劑。  
If the filter is very dirty, use a mild household detergent in the wash water.



待過濾網完全晾乾後，方可重新還原並裝入。

Dry filter thoroughly before re-installing it. Be sure the word "FRONT" is facing you as you slide the filter back into place.

## 進出風口 Inlet & Outlet

空氣受阻將會影響製冷效果。

Check air inlet and outlet of outdoor unit.

Air blockage or obstruction could result in bad efficiency.





## 常見問題及處理方法 TROUBLESHOOTING

在聘請技術人員維修前，請先參考以下程序檢查，以節約時間及金錢。

現象	可能原因
冷氣機完全無法運作	<ul style="list-style-type: none"> <li>- 電源沒有接通</li> <li>- 插頭鬆動</li> <li>- 電源保險絲融斷或開關沒有開啟</li> <li>- 電壓高於253V或低於198V</li> <li>- 定時設定不正確</li> </ul>
製冷效果不佳	<ul style="list-style-type: none"> <li>- 冷氣機進風口或出風口被堵塞</li> <li>- 在房內有其它熱源</li> <li>- 過濾網過度骯髒</li> <li>- 風速設定過低</li> <li>- 溫度設定不正確</li> </ul>
有霧氣排出	- 在制冷或除濕模式下，室內機有薄霧散出, 這是由於室內潮濕空氣驟降而形成的正常現象
冷氣機運作時有噪音	<ul style="list-style-type: none"> <li>- 若雜音像流水：這是冷氣機內雪種流動時的聲音</li> <li>- 若雜音像灑水：這是冷氣機內散熱系統運作時的聲音</li> </ul>
冷氣機重新啟動時未能立即運作	- 當冷氣機被關掉再重開時，系統會自動暫停3分鐘，作用是保護內部機件
遙控器的顯示屏幕模糊甚至沒有顯示	<ul style="list-style-type: none"> <li>- 遙控器內的電池已耗盡，請更換新電池</li> <li>- 遙控器內的電池沒有按指示之正負極方向放好</li> </ul>

Please check the following items before ask for repair, it saves your time and money.

Problem	Possible Causes
Air conditioner does not operate at all	<ul style="list-style-type: none"> <li>- There is a power outage</li> <li>- The unit is unplugged</li> <li>- Power fuse or power switch is broken</li> <li>- Voltage is higher than 253 V or lower than 198 V</li> <li>- Timer is not appropriately set</li> </ul>
Cooling efficiency is not good or no cooling occurs at all	<ul style="list-style-type: none"> <li>- Air inlet or outlet is blocked</li> <li>- There is another heat source in the room</li> <li>- Air filter is dirty</li> <li>- Fan speed is set at LOW</li> <li>- Temperature setting is not appropriately set</li> </ul>
Foggy air flows out	- At COOL or DRY mode operation, sometimes there is foggy air flowing out of the unit. This is because humid air is being cooled down rapidly - it is normal
The air conditioner is making noise	<ul style="list-style-type: none"> <li>- For a water-flowing noise: It is the sound of refrigerant flowing inside the unit</li> <li>- For a shower-like noise: It is the sound of the cooling system inside the unit</li> </ul>
Air conditioner does not operate for a while when restart	- The unit is programmed to allow a pause between shutdown and restart to protect the mechanism. Wait about 3 min. and operation will start again
Remote control display is faded or no display at all	<ul style="list-style-type: none"> <li>- The batteries are depleted</li> <li>- The batteries are inappropriately inserted in the wrong (+) and (-) direction</li> </ul>

## 常見問題及處理方法 TROUBLESHOOTING



在出現下列情況時，立即停止所有操作，拔出插頭，並聯系德國寶維修及顧客服務部。  
Immediately stop all operations, unplug the unit and contact our Repairs and Customer Service Department in the following situations.

- 自動啟動或者停止運行  
Operation starts and stop abnormally
- 電源保險絲或者開關經常斷開  
Power fuse or power switch breaks often
- 水或者其他東西誤入冷氣機  
Accidentally splash water or liquids into air conditioner
- 電線過熱或者線路外殼破裂  
Electrical cords get very hot or the cover damaged
- 其他異常情況  
Other strange conditions



## 技術規格 TECHNICAL SPECIFICATIONS

型號 Model	WAC-307R	WAC-309R	WAC-312R	WAC-318R
電壓 / 頻率 (伏特 / 赫茲) Voltage/Frequency (V/Hz)	220 - 240 V / 50 Hz			
功率 (千瓦) Power (kW)	0.727 kW	0.91 kW	1.27 kW	1.85 kW
電流 (安培) Current (A)	3.6 A	4.5 A	6.2 A	9.3 A
製冷能力 (千瓦) Cooling Capacity (kW)	2.00 kW	2.50 kW	3.50 kW	5.28 kW
抽濕能力 (公升/小時) Dehumidification Capacity (L/hr)	1.2 L/hr	1.5 L/hr	1.6 L/hr	2.0 L/hr
空氣流量 (立方米/小時) Airflow Volume (m <sup>3</sup> /hr)	360 m <sup>3</sup> /hr	360 m <sup>3</sup> /hr	480 m <sup>3</sup> /hr	700 m <sup>3</sup> /hr
製冷劑 Refrigerant	R410A	R410A	R410A	R410A
尺寸 (毫米) Dimensions (mm)	(H) 350 mm (W) 450 mm (D) 580 mm	(H) 350 mm (W) 450 mm (D) 580 mm	(H) 375 mm (W) 560 mm (D) 618 mm	(H) 428 mm (W) 660 mm (D) 700 mm
噪音(分貝) Sound Level (dB) (Inside/Outside)	52 / 59 dB	52 / 59 dB	53 / 61 dB	55 / 65 dB
淨重 (公斤) Net Weight (kg)	35 kg	36 kg	48 kg	60 kg

產品規格及設計如有變更，恕不另行通知。  
Specifications are subject to change without prior notice.

中英文版本如有出入，一概以中文版為準。  
If there is any inconsistency or ambiguity between the English version and the Chinese version, the Chinese version shall prevail.

本產品使用說明書以 [www.germanpool.com](http://www.germanpool.com) 網上版為最新版本。  
Refer to [www.germanpool.com](http://www.germanpool.com) for the most up-to-date version of the Operating Instructions.

請填妥以下空格並與發票一併保存，以便維修時核對資料。用戶提供本公司之所有資料必須正確無誤，否則免費保用將會無效。  
Please fill out the form below. This information and the purchase invoice will be required for any repairs. Warranty will be invalid if information provided is found to be inaccurate.

型號 Model No. :  WAC-307R  WAC-309R  WAC-312R  WAC-318R

機身號碼 Serial No. : \_\_\_\_\_ 發票號碼 Invoice No. : \_\_\_\_\_

購買商號 Purchased From : \_\_\_\_\_ 購買日期 Purchase Date : \_\_\_\_\_

## 保用條款

此保用提供德國寶產品之機件在正常使用下三年全機零件及五年壓縮機保用(自購買日起計算)。

\* 貴戶須在購機十天內，以下列其中一種方式向本公司登記資料，保用手續方正式生效：

- 1) 填妥本公司網頁內之保用登記表格 [www.germanpool.com/warranty](http://www.germanpool.com/warranty)。
- 2) 填妥保用登記卡，並連同購機發票之副本一併郵寄到客戶服務部 (本公司將不發還發票副本或登記卡)。

1. 未能出示購買發票正本者，將不獲免費維修服務。
2. 用戶應依照說明書的指示操作。本保用並不包括：
  - 安裝、上門檢驗、更換零件之人工或運輸費用等；
  - 因天然與人為意外造成的損壞 (包括運輸及其他)；
  - 電源接合不當、不依說明書而錯誤或疏忽使用本機所引致之損壞。
3. 於下列情況下，用戶之保用資格將被取消：
  - 購買發票有任何非認可之刪改；
  - 產品被用作商業或工業用途；
  - 產品經非認可之技術人員改裝或加裝任何配件；
  - 機身編號被擅自塗改、破壞或刪除。
4. 總代理有權選擇維修或更換配件或其損壞部份。
5. 產品一經被轉讓，其保用即被視作無效。

## 客戶服務部

德國寶(香港)有限公司  
香港九龍土瓜灣馬頭角道116號  
新寶工商中心高層地下2-4室  
電話：+852 2333 6249  
傳真：+852 2356 9798  
電郵：repairs@germanpool.com

## Warranty Terms & Conditions

Under normal operations, the product will receive a 3-year parts replacement warranty & 5-year compressor warranty provided by German Pool (effective starting from the date of purchase).

\* This warranty is not valid until Customer's registration information is returned to and received by our Service Centre within 10 days of purchase via one of the following methods:

- 1) Visit our website and register online: [www.germanpool.com/warranty](http://www.germanpool.com/warranty).
- 2) Complete all fields on the attached Warranty Card and mail it back to our Customer Service Centre along with a photocopy of the purchase invoice (Warranty Card and invoice copy will not be returned to Customer).

1. Customer who fails to present original purchase invoice will be disqualified for free warranty.
2. Customer should always follow the operating instructions. This warranty does not apply to:
  - labour costs for installation, on-site check-up, replacement of parts and other transportation costs;
  - damages caused by accidents of any kind (including transport and others);
  - operating failures resulted from incorrect voltage, improper operations and unauthorized installations or repairs.
3. This warranty is invalid if:
  - purchase invoice is modified by unauthorized party;
  - product is used for any commercial or industrial applications;
  - product is repaired or modified by unauthorized personnel, or unauthorized parts are installed;
  - serial number is modified, damaged or removed from the product.
4. German Pool will, in its discretion, repair or replace any defective part.
5. This warranty will be void if there is any transfer of ownership from the original purchaser.

## Customer Service Centre

German Pool (Hong Kong) Limited  
Room 2-4, Upper G/F, Newport Centre,  
116 Ma Tau Kok Road,  
Tokwawan, Kowloon, Hong Kong  
Tel : +852 2333 6249  
Fax : +852 2356 9798  
Email : repairs@germanpool.com

**GERMAN**  
POOL  **德國寶**

德國寶 ( 香港 ) 有限公司 German Pool (Hong Kong) Limited

中國香港總代理 Hong Kong, China Sole Agent

九龍土瓜灣馬頭角道116號新寶工商中心高層地下2-4號室  
Room 2-4, Upper G/F, Newport Centre, 116 Ma Tau Kok Road,  
Tokwawan, Kowloon

電話 Tel: +852 2333 6245 傳真 Fax: +852 2765 8215

中國內地總代理 Mainland China Sole Agent

廣東省佛山市順德區大良南國東路德順廣場三層  
3/F, Takshun Plaza, Nanguo East Road, Shunde,  
Foshan, Guangdong

電話 Tel: +86 757 2980 8308 傳真 Fax: +86 757 2980  
8318



© 版權所有。未獲德國寶授權，不得翻印、複製或使用本說明書作任何商業用途，違者必究。

© All rights reserved. Copying, reproducing or using the contents of this manual is not allowed without prior authorization from German Pool, violators will be prosecuted.

[www.germanpool.com](http://www.germanpool.com)