

GERMAN
POOL



德國寶

座檯式電風扇

Free-standing Electric Fan

EFT-312
EFT-316

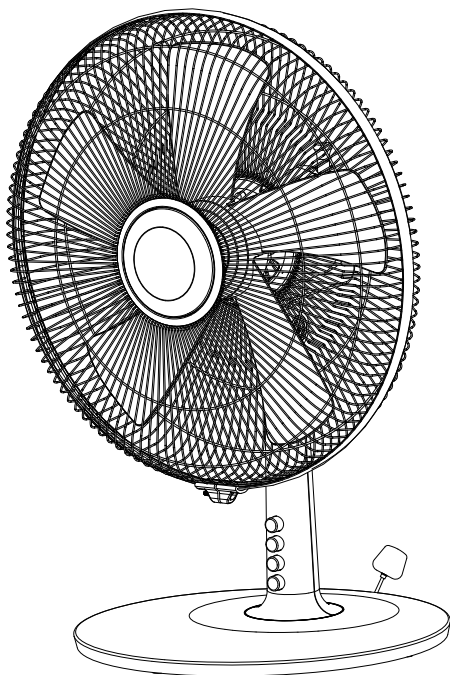

在使用之前請詳細閱讀「使用說明書」及「保用條款」，並妥為保存。

Please read these instructions and warranty information carefully before use and keep them handy for future reference.

使用說明書 USER MANUAL

請即進行保用登記!

有關保用條款細則，請看本說明書最後一頁。

Please register your warranty information now !

**For Warranty Terms & Conditions,
please refer to the last page of these User Manual.**

目錄 Content

注意事項 Notice Before Use 04

產品結構 Product Structure 05

操作說明 Operating Instructions 06

清潔與保養 Care & Maintenance 08

疑難排解 Troubleshooting Guidelines 09

技術規格 Technical Specifications 09

保用條款 Warranty Terms & Conditions 11

注意事項 Notice Before Use

1. 在使用該電器前請仔細閱讀此說明書。
2. 拆開包裝後，請檢查機體是否被損壞；如果對產品質量有任何懷疑請立即諮詢供應商。
3. 勿讓兒童玩弄諸如塑膠袋之類的包裝材料。
4. 在插插頭前須先檢查供應電壓是否與本電器電壓標上所注的電壓相符合。
5. 在安裝或拆卸本機之前須確保插頭沒有接通電源。
6. 拔掉插頭前須先切斷電源。
7. 在風扇工作的過程中禁止將任何物體插入扇網內，這會給人帶來嚴重傷害。
8. 該風扇應在氣候溫和時使用，請勿在潮濕或灰塵多的地方使用，勿在酸性或鹼性的條件下使用。
9. 勿將衣物掛在風扇上。
10. 勿在戶外使用該電器。
11. 嬰兒或病人請勿長時間對著風扇吹。
12. 請勿在沒有大人監管的情況下使用本機。
13. 請勿讓小孩玩弄本機。
14. 本機不適合有缺陷、有智力問題的人或是無操作經驗的人使用，除非有監管人或是在指導下使用。
15. 八歲或以上的兒童或者有缺陷以及有智力問題的人在有監督或者被告知安全使用方法且瞭解潛在危害的情況下可以使用本產品。兒童不能把玩本產品，兒童做清潔維護時要人監督。
16. 如果電源軟線損壞，為避免危險，必須由製造廠或其維修部或類似的專職人員來更換。
1. Read all instructions carefully before you use the appliance.
2. Remove the packages and ensure that the appliance is undamaged. In case of doubt do not use the fan and contact with your supplier.
3. Do not let children play with parts of the packages (such as plastic bags).
4. Before plugging to the socket, check that if the voltage of your main supply matches the voltage marked on the rating label of the appliance.
5. Before assembling or dismantling the fan, make sure that the fan is unplugged.
6. Before unplugging the power cord, turn off the switch.
7. Do not insert any object into the guard while the fan is operating. IT WILL CAUSE INJURY TO THE PERSON.
8. The fan shall be used for temperate climates, do not use the fan at the high humidity area or dusty area. Do not use the fan where acid or alkali is stored.
9. Do not hang any clothes on the fan guards.
10. Do not use the fan outdoors.
11. Do not continuously to blow the baby or the patient directly for a long time.
12. The appliance is not intended for use by young children or infirm persons without supervision.
13. Children should be supervised to ensure that they do not play with the appliance.
14. This appliance is not intended for use by persons (including children) with reduced physical, sensory or mental capabilities, or lack of experience and knowledge, unless they have been given supervision or instruction concerning use of the appliance by a person responsible for their safety.
15. This appliance can be used by children aged from 8 years old and above and persons with reduced physical, sensory or mental capabilities or lack of experience and knowledge if they have been given supervision or instruction concerning use of the appliance in a safe way and understand the hazards involved. Children shall not play with the appliance. Cleaning and user maintenance shall not be made by children without supervision.
16. If the supply cord is damaged, it must be replaced by the manufacturer, its service agent or similarly qualified persons in order to avoid a hazard.

產品結構 Product Structure

主機 Main Body

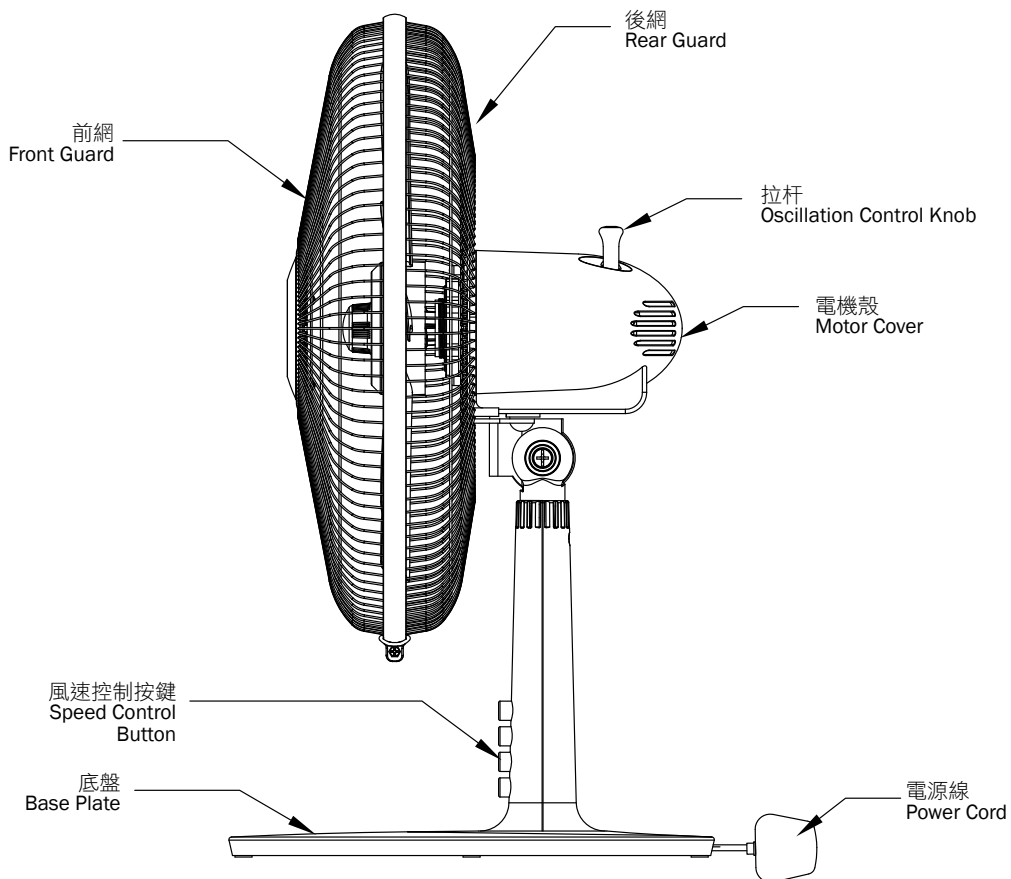

操作說明 Operating Instructions

組裝方法

1. 將螺母和網束從電機軸上取下。
2. 將後網對準電機前殼的定位支柱套入。再用網束把後網固定在機身上。
3. 對準插槽將風扇葉套到電機軸上，再逆時針鎖緊螺母，固定好風葉。手動檢查風葉 轉動是否順暢。
4. 鬆開前網底部的網環螺絲，放鬆網環；從後網頂部開始套入前網，按壓前網周邊使前後網完全吻合，鎖緊網環螺絲，收緊網環。

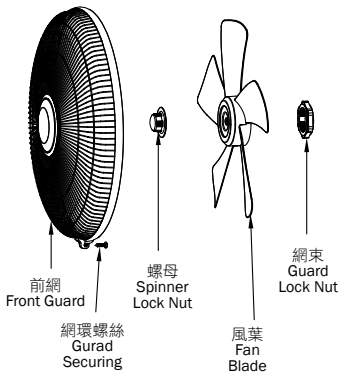

5. 底座組裝

將電源線卡到底盤的缺口處，將立柱的凸點與底盤內的缺口處對齊，插入後順時針擰緊。

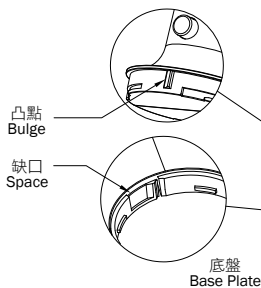

Assembly Desk Fan

1. Remove the spinner lock nut and guard lock nut from the motor shaft spindle.
2. Fit the rear guard, by the positioning on the location pins. Secure the guard to the motor body with the guard lock nut.
3. Push the fan blade onto the motor shaft by matching the slots on the base of the blade with the shaft pin. Secure the blade with the spinner lock nut. The spinner lock nut must be tightened by turning it in a counter-clockwise direction. Check that the fan blade rotates freely by turning with your hand.
4. Open the securing clip at the bottom of the front guard and loosen the clip screw. Position the top clip on the uppermost part of the rear guard. Push the top clip down and press rim of the front guard onto the rear guard. Close the bottom clip and tighten the screw.

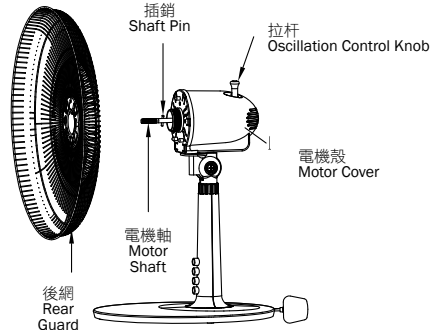

5. Base assemblies

Put power cord into the base hole and set the bulge of stand tube alignment with space of base hole, and turn the stand tube by clockwise direction.

1. 將電源線卡到底盤在缺口處，將立柱在凸點與底盤內的缺口處對齊。
Put power cord into the base hole and set the bulge of stand tube alignment with space of hole.

2. 逆時針方向旋轉。
Turning in a counter-clockwise direction.

操作說明 Operating Instructions

重要提示

不要在浴室或潮濕的地方使用。可將風扇放置在架上、枱上或櫃頂，並需靠近電源插頭，注意放置位置平整使風扇穩定。並要在兒童不能接觸到的位置，不要將任何物品插入網罩內。如需要移動風扇，請關閉風扇拔掉插頭。

IMPORTANT

Do not use in the bathroom or damp location. Decide on a location for the fan, on a shelf, desk, table or cabinet top, convenient to a supply socket. Be sure the location is level so that the fan is stable. Position the fan out of reach of children. Do not insert anything into the guard grille. If moving the fan to a different location, switch off and unplug from the mains.

按鍵說明

按風速鍵可控制吹風速度。

CONTROLS

Push the speed button to control the air flow speed.

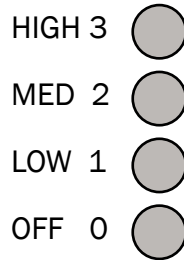

上下調節

風扇的上下角度，可用手從風扇的網罩頂部往下按，或將網罩從底部往上抬高調校。

TILTING

The desk fans can be adjusted for a desired tilt with your hand.

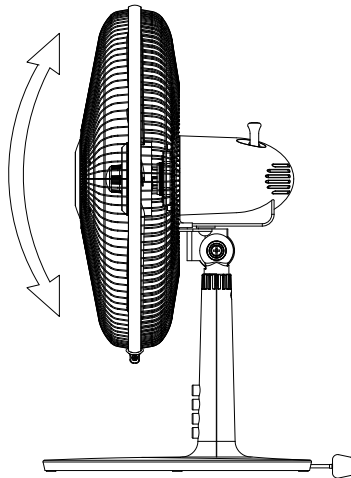

操作說明 Operating Instructions

左右搖頭

按下拉杆，風扇開始搖頭。
拉起拉杆，風扇停止搖頭。
為避免衣物進入網罩內，請不要在風扇正面操作拉杆。

OSCILLATION

The oscillation control knob is positioned on the top of the motor housing. Press the knob down to make the fan oscillate, pull it up to stop the oscillation. When operating this control we suggest that it is best not to reach across the front of the fan. There is the possibility of clothing, sleeves, etc, entering the front guard.

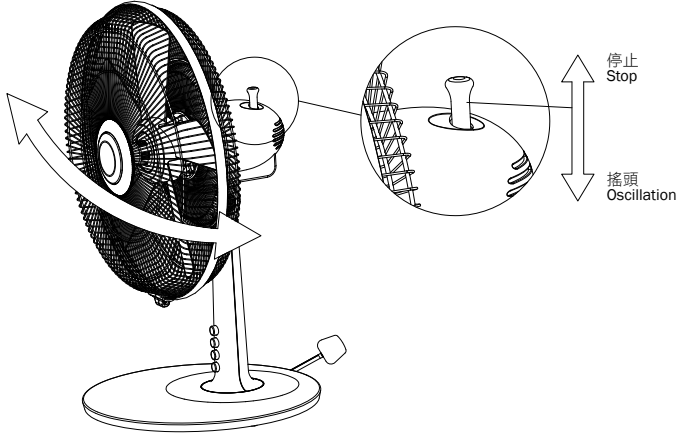

清潔與保養 Care & Maintenance

清潔

1. 清潔前請先關掉電源，拔掉電源插頭。
2. 使用柔軟的乾布來清理機身，如果機身非常髒，可用濕布來清潔。
3. 不要使用任何清潔劑、噴劑或其他化學劑，因為這些對風扇有害。

CLEANING

1. Turn off and unplug the appliance before cleaning.
2. Clean the surface of the appliance with dry cloth. If it's very dirty, please use wet cloth.
3. Do not use any detergent, spray or chemicals to clean the appliance to avoid any damage.

儲存

- 清潔後請按以下步驟來儲存風扇：
1. 用適量潤滑油塗在電機軸上防止生鏽。
 2. 去掉機身上的油漬和汙漬。
 3. 用原包裝裝好放在通風乾燥的地方。

STORAGE

- Please follow the steps as below to store the fan after cleaning:
1. Put several lubricant into the motor shaft to avoid rusty.
 2. Make sure all the greasiness and grime is out of the surface of the appliance.
 3. Please follow the original packing to keep the fan properly stored at a dry place.

疑難排解 Troubleshooting Guidelines

狀況 Trouble	檢查事項 Inspection
風扇開啟時風葉未轉動 The fan blade does not rotate when turned-on	1. 電源線插頭是否正確的插入插座。 Check if the supply cord is properly connected to the supply. 2. 網罩是否觸及到風葉。 Check the fan guard and the fan blade if it is touching or hitting each other.
風扇啟動時有異響 There is abnormal sound when starting the fan	1. 風葉是否正確裝入電機軸上，風葉是否套到底。 Check if the fan blade is properly attached to the rotor shaft with respect to the rotor pin. 2. 風葉是否有毛邊或變形，觸及到網罩。 Check if there are burrs or damage on the fan blade causing it to touch or hit the fan guard. 3. 網罩是否變形觸及到風葉。 Check if the fan guard are deformed or touching the fan blade.

技術規格 Technical Specifications

型號 Model	EFT-312	EFT-316
電壓 Voltage	220-240V	
頻率 Frequency	50Hz	
功率 Power	40W	50W

產品規格及設計如有變更，恕不另行通知。
Specifications are subject to change without prior notice.

中英文版本如有出入，一概以中文版為準。
If there is any inconsistency or ambiguity between the English version and the Chinese version, the Chinese version shall prevail.

本產品使用說明書以 www.germanpool.com 網上版為最新版本。
Refer to www.germanpool.com for the most up-to-date version of the User Manual.

如欲獲取更多有關本產品最新資訊，歡迎瀏覽本公司網站。
For additional product information, please visit our website.

www.germanpool.com

請填妥以下空格並與發票一併保存，以便維修時核對資料。用戶提供本公司之所有資料必須正確無誤，否則免費保用將會無效。
Please fill out the form below. This information and the purchase invoice will be required for any repairs. Warranty will be invalid if information provided is found to be inaccurate.

型號 Model No. : EFT-312 EFT-316

機身號碼 Serial No. : _____ 發票號碼 Invoice No. : _____

購買商號 Purchased From : _____ 購買日期 Purchase Date : _____

保用條款

此保用提供德國寶產品之機件在正常使用下壹年保用(自購買日起計算)。

* 貴戶須在購機十天內，以下列其中一種方式向本公司登記資料，保用手續方正式生效：

- 1) 填妥本公司網頁內之保用登記表格 www.germanpool.com/warranty。
- 2) 填妥保用登記卡，並連同購機發票傳真至客戶服務部。

1. 未能出示購買發票正本者，將不獲免費維修服務。
2. 用戶應依照說明書的指示操作。本保用並不包括：
 - 上門安裝、檢驗、維修或更換零件之人工以及一切運輸費用；
 - 因天然與人為意外造成的損壞(包括運輸及其他)；
 - 任何塑膠附件及輔助裝置；
 - 電源接合不當、不依說明書而錯誤或疏忽使用本機所引致之損壞。
3. 於下列情況下，用戶之保用資格將被取消：
 - 購買發票有任何非認可之刪改；
 - 產品被用作商業或工業用途；
 - 產品經非認可之技術人員改裝或加裝任何配件；
 - 機身編號被擅自塗改、破壞或刪除。
4. 總代理有權選擇維修或更換配件或其損壞部份。
5. 產品一經被轉讓，其保用即被視作無效。

客戶服務及維修中心

德國寶(香港)有限公司
香港九龍紅磡暢通道 1 號
中旅貨運物流中心8樓
電話：+852 2333 6249
傳真：+852 2356 9798
電郵：repairs@germanpool.com

Warranty Terms & Conditions

Under normal operations, the product will receive a 1-year full warranty by German Pool (effective starting from the date of purchase).

* This warranty is not valid until Customer's registration information is returned to and received by our Service Centre within 10 days of purchase via one of the following methods:

- 1) Visit our website and register online: www.germanpool.com/warranty.
- 2) Complete all fields on the attached Warranty Card and fax it back to our Customer Service Centre along with the purchase invoice.

1. Customer who fails to present original purchase invoice will be disqualified for free warranty.
2. Customer should always follow the operating instructions. This warranty does not apply to:
 - labour costs for on-site installation, check-up, repair, replacement of parts and other transportation costs;
 - damages caused by accidents of any kind (including transport and others);
 - plastic parts and accessories;
 - operating failures resulted from incorrect voltage, improper operations and unauthorized installations or repairs.
3. This warranty is invalid if:
 - purchase invoice is modified by unauthorized party;
 - product is used for any commercial or industrial applications;
 - product is repaired or modified by unauthorized personnel, or unauthorized parts are installed;
 - serial number is modified, damaged or removed from the product.
4. German Pool will, in its discretion, repair or replace any defective part.
5. This warranty will be void if there is any transfer of ownership from the original purchaser.

Customer Service & Repair Centre

German Pool (Hong Kong) Limited
8/F, China Travel (Cargo) Logistics Centre
1 Cheong Tung Road
Hung Hom, Kowloon, Hong Kong
Tel : +852 2333 6249
Fax : +852 2356 9798
Email : repairs@germanpool.com

此保用只適用於香港

This warranty is valid only in Hong Kong

GERMAN POOL 德國寶

德國寶 (香港) 有限公司 German Pool (Hong Kong) Limited

中國香港 Hong Kong, China

香港九龍土瓜灣馬頭角道116號
新寶工商中心2期113號室
Room 113, Newport Centre Phase II, 116 Ma Tau
Kok Road, Tokwawan, Kowloon, Hong Kong.
電話 Tel: +852 2773 2888
傳真 Fax: +852 2765 8215

中國內地 Mainland China

廣東省佛山市順德區
大良南國東路德順廣場三層
3/F, Takshun Plaza, Nanguo East Road,
Shunde, Foshan, Guangdong
電話 Tel: +86 757 2980 8308
傳真 Fax: +86 757 2980 8318

中國澳門 Macau, China

澳門宋玉生廣場263號
中土大廈15樓1座
Alameda Dr. Carlos D'Assumpcao No. 263,
Edif. China Civil Plaza, 15 Andar, I. Macau
電話 Tel: +853 2875 2699
傳真 Fax: +853 2875 2661



香港名牌十年成就獎
HONG KONG TOP BRAND TEN YEAR
ACHIEVEMENT AWARD



香港最著名牌
HONG KONG
PREMIER BRAND



2007
CERTIFICATE AWARD FOR THE BEST BRAND ENTERPRISE
年度最佳品牌企業



中小企業
最佳拍檔大獎



© 版權所有。未獲德國寶授權，不得翻印、複製或使用本說明書作任何商業用途，違者必究。

© All rights reserved. Copying, reproducing or using the contents of this manual is not allowed without prior authorization from German Pool, violators will be prosecuted.

www.germanpool.com