

Portable Air Conditioner | PAC-208

此檔僅供預覽，勿用作印刷

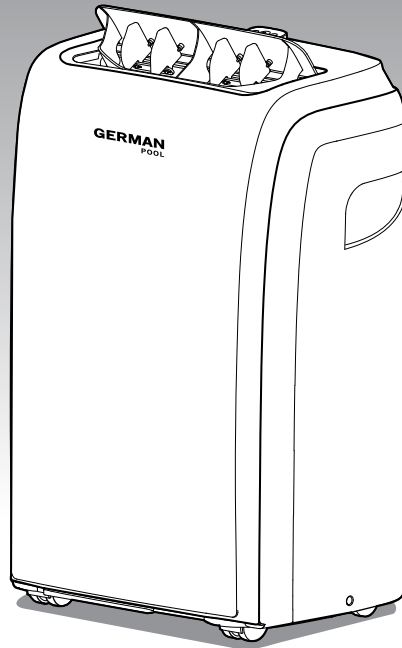

Online Warranty Registration



Please read these instructions and warranty information carefully before use and keep them handy for future reference.

USER MANUAL

Tables of Contents

請即進行保用登記！
有關保用條款細則，請看說明書最後一頁。

Please register your warranty information now !
For Warranty Terms & Conditions,
please refer to the last page of this user manual.

Safety Instructions	4
Product Structure	7
Installation Instructions	8
Operating Instructions	11
Care and Maintenance	23
Troubleshooting	24
Technical Specification	26
Environment and Recycling	26
Warranty Terms & Conditions	51

Safety Instructions

- The appliance is not intended for use by persons (including children) with reduced physical, sensory or mental capabilities, or lack of experience and knowledge, unless they have been given supervision or instruction concerning use of the appliance by a person responsible for their safety.
- Children should be supervised to ensure that they do not play with the appliance.
- This appliance can be used by children aged from 8 years and above and persons with reduced physical, sensory or mental capabilities or lack of experience and knowledge if they have been given supervision or instruction concerning use of the appliance in a safe way and understand the hazards involved.
- Children shall not play with the appliance.
- Cleaning and user maintenance shall not be made by children without supervision.
- Keep the appliance and its cord out of reach of children aged less than 8 years.
- Disconnect the appliance from its power source during service and when replacing parts.
- Warning: before obtaining access to terminals, all supply circuits must be disconnected.
- If the supply cord is damaged, it must be replaced by the manufacturer, its service agent or a similarly qualified person in order to avoid a hazard.
- Disconnect the power supply before cleaning and maintenance.
- The appliance shall not be installed in the laundry.
- Do not use this unit for functions other than those described in this instruction manual.
- If the power cord becomes worn or damaged, the cord should only be replaced by a qualified service technician using genuine replacement parts.
- Make sure the plug is plugged firmly and completely into the outlet. It can result in the risk of electric shock or fire.
- Do not plug other appliances into the same outlet, it can result in the risk of electric shock.
- Do not disassemble or modify the appliance or the power cord, it can result in the risk of electric shock or fire. All other services should be referred to a qualified technician.
- Do not place the power cord or appliance near a heater, radiator, or other heat source. It can result in the risk of electric shock or fire.
- This unit is equipped with a cord that has a earthed wire connected to an earthed pin or grounding tab. The plug must be plugged into a socket that is properly installed and earthed. Do not under any circumstances cut or remove the earthed pin or grounding tab from this plug.
- The unit should be used or stored in such a way that it is protected from moisture e.g. condensation, splashed water, etc. Unplug unit immediately if this occurs.
- Always transport your appliance in a vertical position and place on a stable, level surface during use. If the unit is transported laying on its side it should be stood up and left unplugged for 6 hours.

Safety Instructions

- Always use the switch on the control panel to turn the unit or remote control off, and do not start or stop operation by plugging in or unplugging the power cord. It can result in the risk of electric shock.
- Do not press the buttons on the control panel with your wet or damp fingers.
- Do not use hazardous chemicals to clean or come into contact with the unit. To prevent damage to the surface finish, use only a soft cloth to clean the appliance. Do not use wax, thinner, or a strong detergent. Do not use the unit in the presence of inflammable substance or vapour such as alcohol, insecticides, gasoline, etc.
- Young children should be supervised to ensure that they do not play with, operate or climb on the appliance.
- If the appliance is making unusual sounds or is emitting smoke or an unusual odor, unplug it immediately.
- Do not clean the unit with water. Water can enter the unit and damage the insulation, creating a shock hazard. If water enters the unit, unplug it immediately and contact Customer Service.
- Utilize two or more people to lift and install the unit.
- Be sure all accessories are removed from the packing before use.
- To avoid possible cuts, avoid contacting the metal parts of the appliance when removing or re-installing the filter. It can result in the risk of personal injury.
- Do not block the air inlet or outlet of the appliance. Reduced airflow will result in poor performance and could damage the unit.
- Always grasp the plug when plugging in or unplugging the appliance. Never unplug by pulling on the cord. It can result in the risk of electrical shock and damage.
- Install the appliance on a sturdy, level floor capable of supporting up to 110lbs(50kg). Installation on a weak or uneven floor can result in the risk of property damage and personal injury.
- Close all doors and windows to the room for most efficient operation.
- When indoor relative humidity is over 80%, the occurrence of condensation on front grille is normal during air con operation. If you wish to reduce the condensation, adjust air vent angle to the largest, fan speed to the highest, and temperature to a higher level accordingly.

Safety Instructions

IMPORTANT - GROUNDING METHOD

This product is factory equipped with a power supply cord that has a three pronged grounded plug. It must be plugged into a mating grounding type receptacle in accordance with the National Electrical Code and applicable local codes and ordinances. If the circuit does not have a grounding type receptacle, it is the responsibility and obligation of the customer to exchange the existing receptacle in accordance with the National Electrical Code and applicable local codes and ordinances. The third ground prong should not, under any circumstances, be cut or removed. Never use the cord, the plug or the appliance when they show any sign of damage. Do not use your appliance with an extension cord unless it has been checked and tested by a qualified electrical supplier. Improper connection of the grounding plug can result in risk of fire, electric shock and/or injury to persons associated with the appliance. Check with a qualified service representative if in doubt that the appliance is properly grounded.

Electrical Connections

Before plugging the appliance into the mains socket, check that:

- The mains power supply corresponds to the value indicated on the rating plate on the back of the appliance;
- The power socket and electrical circuit are adequate for the appliance;
- The mains socket matches the plug. If this is not the case, have the plug replaced;
- The mains socket is adequately earthed. Failure to follow these important safety instructions absolves the manufacturer of all liability.

Product Structure

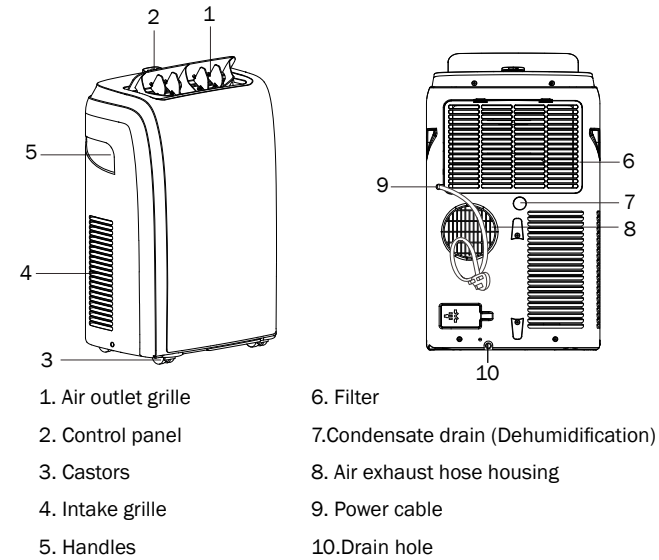

Accessories

Parts	Parts Name	Quantity
	Exhaust hose Hose inlet Hose outlet	1 set
	Window slider kit	1 set
	Remote control with battery	1 set
	Drainage hose	1 set

Note: All the illustrations in this manual are for explanatory purposes only. Your appliance may be slightly different.

Installation Instructions

Exhausting Hot Air

In the Cool Mode the appliance must be placed close towards a window or opening so that the warm exhaust air can be vented outside.

First, position unit on a flat floor and make sure there's a minimum of 12" (30cm) clearance around the unit, and is within the vicinity of a single circuit outlet power source.

1. Extend either side of the hose (Fig.1) and screw the hose inlet (Fig.2).
2. Extend the other side of the hose and screw it to the hose outlet (Fig.3).
3. Install the hose inlet into the unit (Fig.4).
4. Affix the hose outlet into the window slider kit and seal. (Fig.5&6).

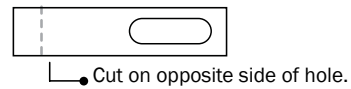
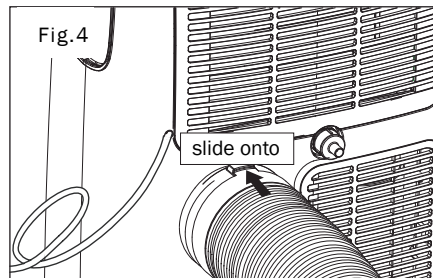
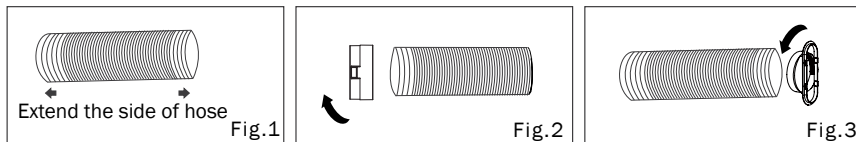

Installation Instructions

Your window slider kit has been designed to fit most standard vertical and horizontal window applications however, it may be necessary for you to modify some aspects of the installation procedures for certain types of windows. The window slider kit can be fastened with screws.

NOTE: If the window opening is less than the minimum length of the window slider kit, cut the end without the hole in it short enough to fit in the window opening. Never cut out the hole in window slider kit.

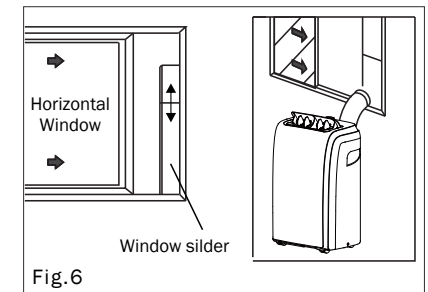
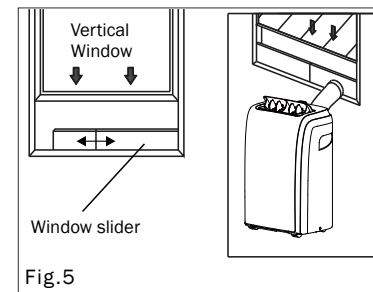

Installation Instructions

Window Slider kit Installation

1: Parts:

- A) Panel
- B) Panel with one hole
- C) Panel without hole (maybe not supplied)
- D) Screw to lock window kit in place

2: Assembly:

Slide Panel B and C into Panel A and size to window width. Windows sizes vary. When sizing the window width, be sure that the window kit assembly is free from gaps and/or air pockets when taking measurements.

3: Lock the screw into the holes that correspond With the width that your window requires to ensure that there are no gaps or air pockets in the window kit assembly after installation.

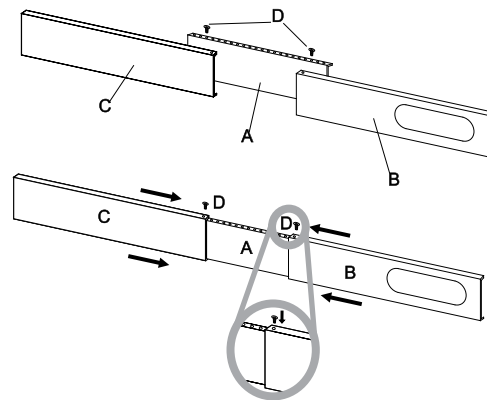

LOCATION

- The unit should be placed on a firm foundation to minimize noise and vibration. For safe and secure positioning, place the unit on a smooth, level floor strong enough to support the unit.
- The unit has casters to aid placement, but it should only be rolled on smooth, flat surfaces. Use caution when rolling on carpeted surfaces. Use caution and Protect floors when rolling over wood floors. Do not attempt to roll the unit over objects.
- The unit must be placed within reach of a properly rated grounded socket.
- Never place any obstacles around the air inlet or outlet of the unit.
- Allow at least 30cm of space away from the wall for efficient air conditioning.
- The hose can be extended, optimized the hose is at minimum length. Also make sure that the hose does not have any sharp bends or sags.

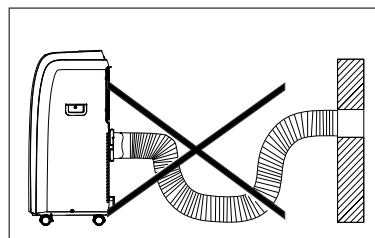
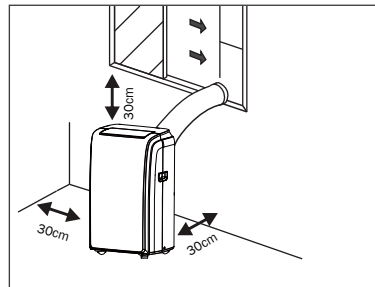

Operating Instructions

DISPLAY

- 1 COOL symbol
- 2 FAN Speed indicator
- 3 TIMER symbol
- 4 Temperature symbol
- 5 Temperature indicator

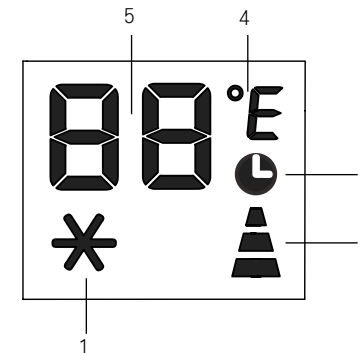

OPERATING FROM THE CONTROL PANEL

The control panel is on the top of the appliance, enables you to manage part functions without remote controller, but to fully utilize all functions, you must use the remote controller.

- 1 ON/OFF button
- 2 MODE button
- 3 FAN button
- 4 INCREASE button
- 5 DECREASE button

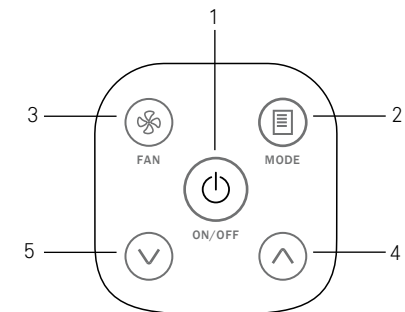

TURNING THE APPLIANCE ON

Plug into the mains socket, then the appliance is standby.

Press the  button to turn on the appliance. The last function active when it was turned off will appear.

Warning





Never turn the appliance off by unplugging from the socket. Always press the , then wait for a few minutes before unplugging. This allows the appliance to perform a cycle of checks to verify operation.

Operating Instructions

COOL mode

Ideal for hot muggy weather when you need to cool and dehumidify the room.

To set this mode correctly:

- Press the  button a number of times until the  symbol appears.
- Select the target temperature 18°C-32°C (64°F-90°F) by pressing the  or  button until the corresponding value is displayed.
- Select the required fan speed by pressing the  button.

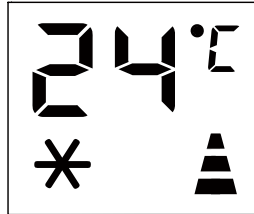

Note: To protect the compression unit, activation will be delayed under cool mode.

Three speeds are available:

 Maximum speed: for maximum fan power

 Medium speed: reduces noise levels but still maintains a good level of comfort



 Low speed: for silent operation

The most suitable temperature for the room during the summer varies from 24°C to 27°C (75°F to 81°F). You are recommended, however, not to set a temperature much below the outdoor temperature. The fan speed difference is more noticeable when the appliance is under FAN mode but may not be noticeable under COOL mode.

FAN mode

Three speeds are available:

When using the appliance in this mode, the air hose does not need to be attached.

- Press the  button a number of times until the  symbol appears.
- Select the required fan speed by pressing the  button.

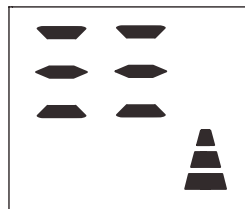

 Maximum speed: for maximum fan power

 Medium speed: reduces noise levels but still maintains a good level of comfort

 Low speed: for silent operation



Operating Instructions

DRY mode

Ideal to reduce room humidity (spring and autumn, damp rain filled periods, etc).

In dry mode, the appliance should be prepared the same way as cool mode, with the air exhaust hose attached to enable the moisture to be discharged outside.

To set this mode correctly:

- Press the  button a number of times until the  symbol appears.
- Select the required fan speed by pressing the  button.

Note: Under dry mode the temperature cannot be adjusted, only wind speed can be adjusted.

Note: When indoor temperature is $\leq 16^\circ\text{C}$, compressor unit will not activate and dry mode will not be available.

Three speeds are available:

 Maximum speed: to achieve the best dehumidify effect.

 Medium speed: can reduce noise level but still maintains a better dehumidify effect.

 Low speed: for silent operation but lowers the dehumidify effect relatively.

During the DRY mode, you will need a garden hose (sold separately) or drainage hose (with unit package) to drain the condensate from the unit.

Follow the steps below:

- Unscrew the drain cap of continuous drain outlet (Fig.7).
- Connect one end of the garden hose (sold separately) or drainage hose (with unit package) to the drain outlet then lead the other end into a drain that is lower than the unit (Fig.8).

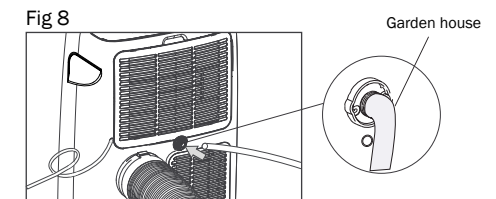
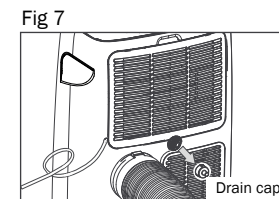

Operating Instructions

Note:

- Condensate may flow out after removing the drain cap, if the unit is running in Cool mode. When you want to remove the garden hose, prepare a drip tray (not supplied) to collect the condensate from the drain outlet.
- Please be sure that the height of the drain and section of the drain hose should not be higher than that of the drain outlet, or the continuous drainage may not work properly.
- During Cool mode, it is recommended to disable continuous drainage by replacing the drain cap to the drain outlet, to reach the maximum performance.

Fig 9

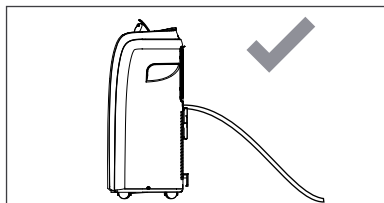
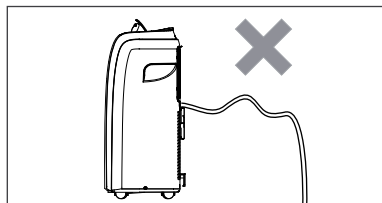



Fig 10



Switch the unit of temperature

When the appliance is standby, press the  button 20 seconds, then you can change the unit of temperature.

For example:

Before change, in cool mode, the screen display like fig11.

After change, in cool mode, the screen display like fig12.

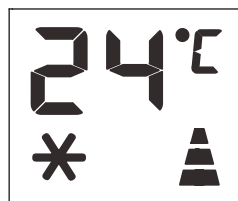

Fig 11

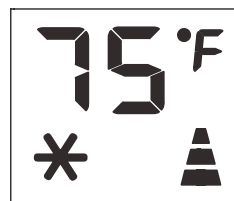







Fig 12

Operating Instructions

OPERATING FROM THE REMOTE CONTROL



-  Fan button
-  Swing button
-  Sleep mode button
-  Increase button
-  Decrease button
-  On/Off button
-  Mode button
-  Timer button
-  °C/°F Unit Switch button

- ✓ Point the remote control at the receiver on the appliance.
- ✓ The remote control must be no more than 7 meters away from the appliance (without obstacles between the remote control and the receiver).
- ✓ The remote control must be handled with extreme care. Do not drop it or expose it to direct sunlight or sources of heat. If the remote control does not work, please try to take out the battery, and put it back.

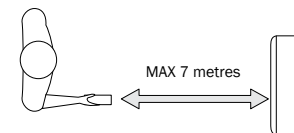

The remote will come with a battery already installed. To use the remote for the first time, remove the transparent insulating strip from the battery housing. By gently pulling it out.

Replacing the Battery

To replace the battery, follow the steps below:

- 1) Press down the pin and remove the battery cover.
- 2) Replace the battery and reinstall the battery cover into the remote controller.

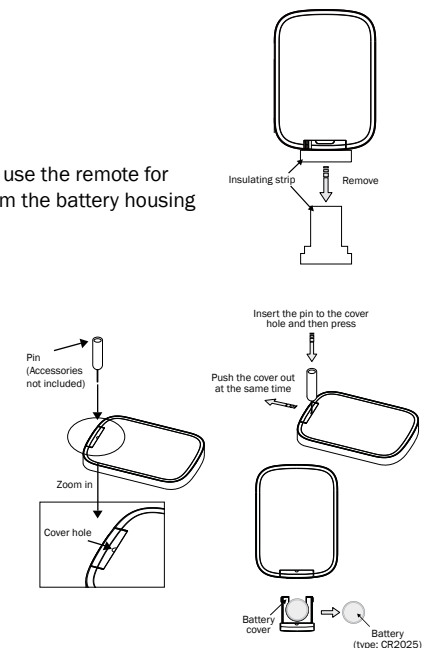





Operating Instructions

COOL mode

Ideal for hot muggy weather when you need to cool and dehumidify the room.

To set this mode correctly:

- Press the  button a number of times until the  symbol appears.
- Select the target temperature 18°C-32°C (64°F-90°F) by pressing the  or  button until the corresponding value is displayed.
- Select the required fan speed by pressing the  button.

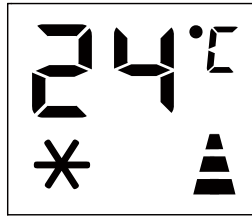

Note: To protect the compression unit, activation will be delayed under cool mode.

Three speeds are available:

 Maximum speed: for maximum fan power



 Medium speed: reduces noise levels but still maintains a good level of comfort

 Low speed: for silent operation

The most suitable temperature for the room during the summer varies from 24°C to 27°C (75°F to 81°F). You are recommended, however, not to set a temperature below the outdoor temperature. The fan speed difference is more noticeable when the appliance is under FAN mode but may not be noticeable under COOL mode.

FAN mode

When using the appliance in this mode, the air hose does not need to be attached.

- Press the  button a number of times until the  symbol appears.
- Select the required fan speed by pressing the  button.

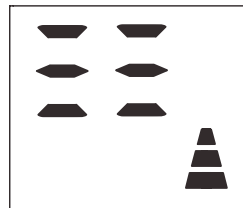

Three speeds are available:

 Maximum speed: for maximum fan power

 Medium speed: reduces noise levels but still maintains a good level of comfort

 Low speed: for silent operation



Operating Instructions

DRY mode

Ideal to reduce room humidity (spring and autumn, damp rooms, rainy periods, etc).

In dry mode, the appliance should be prepared in the same way as cool mode, with the air exhaust hose attached to enable the moisture to be discharged outside.

To set this mode correctly:

- Press the  button a number of times until the  symbol appears.
- Select the required fan speed by pressing the  button.

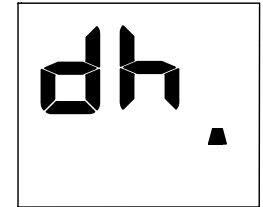



Note: Under dry mode the temperature cannot be adjusted, only wind speed can be adjusted.

Note: When indoor temperature is $\leq 16^{\circ}\text{C}$, compressor unit will not activate and dry mode will not be available.

Three speeds are available:

 Maximum speed: to achieve the best dehumidify effect.

 Medium speed: can reduce noise level but still maintains a better dehumidify effect.

 Low speed: for silent operation but lowers the dehumidify effect relatively.

During the DRY mode, you will need a garden hose (sold separately) or drainage hose (with unit package) to drain the condensate from the unit.

Follow the steps below:

- Unscrew the drain cap of continuous drain outlet (Fig.13).
- Connect one end of the garden hose (sold separately) or drainage hose (with unit package) to the drain outlet then lead the other end into a drain that is lower than the unit (Fig.14).

Fig 13

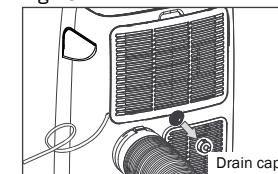
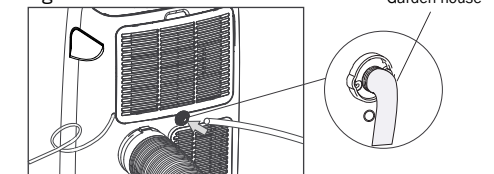

Fig 14



Garden house

Drain cap

Operating Instructions

Note:

- Condensate may flow out after removing the drain cap, if the unit is running in Cool mode. When you want to remove the garden hose, prepare a drip tray (not supplied) to collect the condensate from the drain outlet.
- Please be sure that the height of the drain and section of the drain hose should not be higher than that of the drain outlet, or the continuous drainage may not work properly.
- During Cool mode, it is recommended to disable continuous drainage by replacing the drain cap to the drain outlet, to reach the maximum performance.

Fig 15

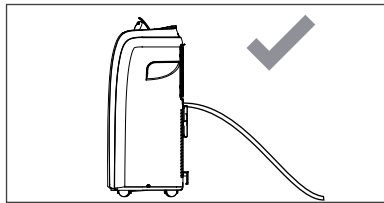
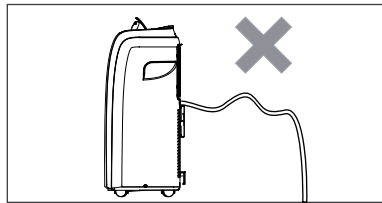



Fig 16



SWING function

This function is useful for select the up/down swing of air Delivery.

To set this function correctly:

- Select the operating mode (cool, dry, fan) as described above.
- Press the  button several times, the deflector will stop different positions or swing continuously.

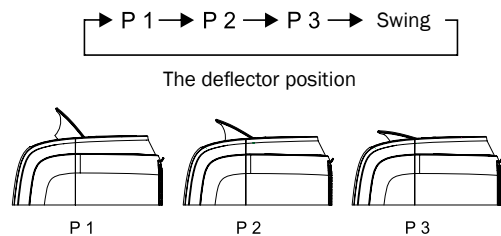

Operating Instructions

SLEEP mode function

This function is useful for the night as it gradually reduces operation of the appliance.

To set this function correctly:

- Select the cool mode as described above.
Press the  button. The appliance operates in the previously selected mode.
- When you choose the sleep function, the screen will be dimmed .

The SLEEP function maintains the room at optimum temperature without excessive fluctuations in either temperature or humidity with silent operation.

Fan speed is always at Low, while room temperature and humidity vary gradually to ensure optimum comfort.

When in COOL mode, the selected temperature will increase by 1°C(1°F) per hour in a 2 hour period. This new temperature will be maintained for the next 6 hours before the appliance shuts off.

The SLEEP function can be canceled at any time during operation by pressing the “Sleep”, “Mode” or “fan speed” button.



In FAN or DRY mode, SLEEP mode function cannot be set.

Switch the unit of temperature

When the appliance is in standby mode, press the °C/°F button, then you can change the unit of temperature.

For example:

Before change, in cool mode, the screen display like fig17.

After change, in cool mode, the screen display like fig18.

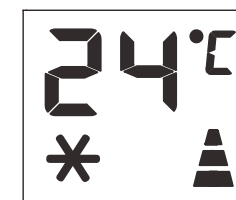

Fig 17

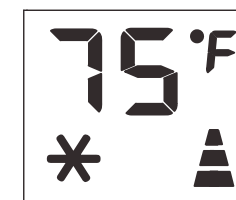









Fig 18

Operating Instructions

TIMER function



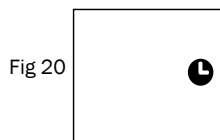
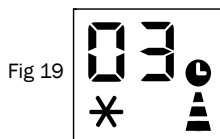

This timer can be used to delay the appliance start-up or shutdown, this optimizes operating periods.

Programming start up

- Turn on the appliance, choose the mode you want, for example cool, 24 °C, high fan speed.
Turn off the appliance.
- Press the  button, the screen will display 1-24 hours, and the  symbol and  symbol and  symbol are flash together. (fig 19)
- Press several times until the corresponding time is displayed. Wait about 5seconds, the timer will be active, then only the  symbol is displayed on screen.(fig 20)
- Press the  button or the  button, the timer will be canceled, and the  symbol will disappear from screen.



Programming shut down

- When the appliance is running, press the  button, the screen will display hours, and several symbols will flash.(fig 21)
- Press several times until the corresponding time is displayed. Wait about 5 seconds, the timer will be active, then only the  symbol is displayed on screen.(fig 22)
- Press again the  button or the  button, the timer will be canceled, and the  symbol will disappear from the screen.

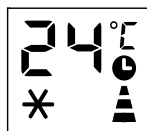

Fig 21

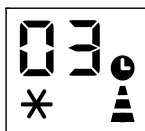

Fig 22

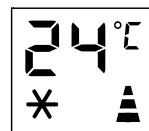

Fig 23

Operating Instructions

Tips For Correct Use

To optimize your appliance follow these recommendations:

- Close the windows and doors in the room to be air conditioned (fig. 24).When installing the appliance semi-permanently, you should leave a door slightly open (as little as 1 cm) to guarantee ventilation;
- Protect the room from direct exposure to the sun by partially closing curtains and/or blinds to make the appliance much more economical to run (fig. 25);
- Never rest objects of any kind on the appliance;
- Do not obstruct the air intake and outlet (fig. 26).

Leave the grilles free;

- Make sure there are no heat sources in the room;
- Never use the appliance in very damp rooms (laundries for example).
- Never use the appliance outdoors.
- Make sure the appliance is standing on a level surface, if necessary, place the castor locks under the front wheels.

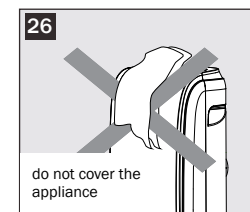
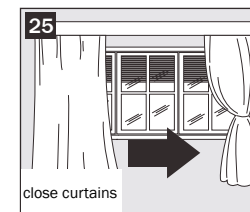
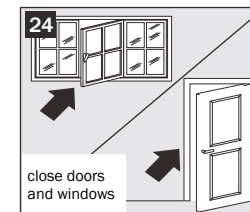

Water Drainage Method

When there is excess water condensation inside the unit, the appliance stops running and shows

“” (FULL TANK as mentioned in SELF-DIAGNOSE).

This indicates that the water condensation needs to be drained using the following procedures:

Manual Draining (fig.27)

Water may need to be drained in high humidity areas

1. Unplug the unit from power source.
2. Place a drain pan (prepared by customer selfs) under the lower drain plug. See diagram.
3. Remove the lower drain plug.
4. Water will drain out and collect in the drain pan (prepared by customer selfs).
5. After the water is drained, replace the lower drain plug firmly.
6. Turn on the unit.

Operating Instructions

Continuous Draining (fig.28)

While using the unit in dehumidifier mode, continuous drainage is recommended.

1. Unplug the unit from the power source.
2. Remove the drain plug. While doing this operation some residual water may spill so please prepare a pan to collect the water.
3. Connect the drain hose (1/2" or 12.7mm, maybe not supplied). See diagram.
4. The water can be continuously drained through the hose into a floor drain or bucket.
5. Turn on the unit.

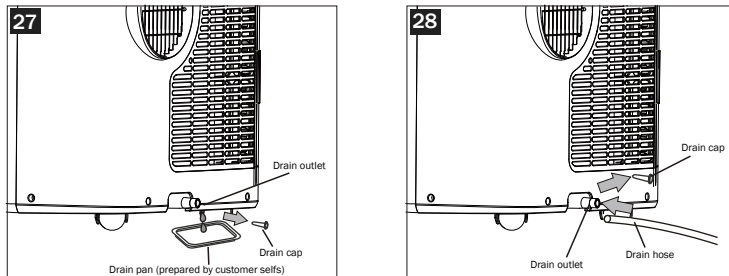

NOTE

Please be sure that the height of and section of the drain hose should not be higher than that of the drain outlet, or the water tank may not be drained. (fig.29 and fig.30)

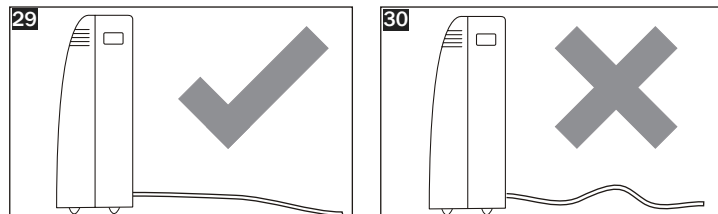

Care And Maintenance

Before cleaning or maintenance, turn the appliance off by pressing the  button on the control panel or remote control, wait for a few minutes then unplug from the main socket.

CLEANING THE CABINET

You should clean the appliance with a slightly damp cloth then dry with a dry cloth.

- Never wash the appliance with water. It could be dangerous.
- Never use petrol, alcohol or solvents to clean the appliance.
- Never spray insecticide liquids or similar.

Watch the video clip

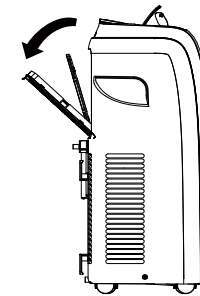

CLEANING THE AIR FILTERE

To keep your appliance efficiently, you should clean the filter weekly.

The evaporator filter can take out like the left fig.

Use a vacuum cleaner to remove dust accumulations from the filter. If it is very dirty, immerse in warm water and rinse a number of times. The water should never be hotter than 40°C(104°F). After washing, leave the filter to dry then attach the intake grille to the appliance.

Start-End Of Season Operations

START OF SEASON CHECKS

Make sure the power cable and plug are undamaged and the earth system is efficient. Follow the installation instructions precisely.

END OF SEASON OPERATIONS

To empty the internal circuit completely of water, remove the cap (fig. 31).

Run off all water left into a basin. When all the water has been drained, put the cap back in place.

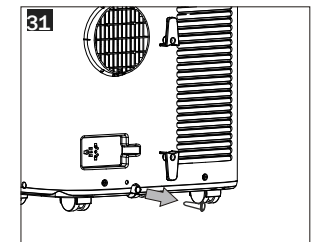

Clean the filter and dry thoroughly before putting back.



Troubleshooting

SELF-DIAGNOSIS

The appliance has a self diagnosis system to identify a number of malfunctions. Error messages are displayed on the appliance display.

If Is Displayed	What Should I Do?
 LOW TEMPERATURE (frost prevention)	<p>The appliance is fitted with a frost protection device to avoid excessive formation of ice.</p> <p>The appliance starts up again automatically when the defrosting process is completed.</p>
 PROBE FAILURE (sensor damaged)	<p>If this is displayed, contact customer service centre.</p>
 FULLTANK (safety tank full)	<p>Empty the internal safety tank, following the instructions in the “End of season operations” paragraph.instructions in the “End of season operations” paragraph.</p>

Troubleshooting

PROBLEM	CAUSE	SOLUTION
The appliance does not switch on	<ul style="list-style-type: none"> • There is no current • It is not plugged in • The internal safety device has tripped 	<ul style="list-style-type: none"> • Wait • Plug into socket • Wait 30 minutes, if the problem persists, contact customer service center
The appliance works for a short time only	<ul style="list-style-type: none"> • There are bends in the air exhaust hose • Something is preventing the air from being discharged 	<ul style="list-style-type: none"> • Position the air exhaust hose correctly, keeping it as short and free of curves as possible to avoid bottlenecks • Check and remove any obstacles obstructing air discharge
The appliance works, but does not cool the room	<ul style="list-style-type: none"> • Windows, doors and/or curtains open • There are heat sources in the room (oven, hairdryer, etc) • The air exhaust hose is detached from the appliance • The technical specification of the appliance is not adequate for the room in which it is located 	<ul style="list-style-type: none"> • Close doors, windows and curtains, bearing in mind the “tips for correct use” given above • Eliminate the heat sources • Fit the air exhaust hose in the housing at the back of the appliance
During operation, there is an unpleasant smell in the room	<ul style="list-style-type: none"> • Air filter clogged 	<ul style="list-style-type: none"> • Clean the filter as described above
The appliance does not operate for about three minutes after restarting it	<ul style="list-style-type: none"> • The internal compressor safety device prevents the appliance from being restarted until three minutes have elapsed since it was last turned off 	<ul style="list-style-type: none"> • Wait. This delay is part of normal operation
The following message appears on the display: Lt/Pf/Ft	<ul style="list-style-type: none"> • The appliance has a self diagnosis system to identify a number of malfunctions 	<ul style="list-style-type: none"> • See the SELF-DIAGNOSIS Chapter

Technical Specifications

Model	PAC-208
Cooling Capacity in BTU	8,000 BTU/hr
Rated Power(Cooling)	1,010W
Rated Voltage/Frequency	220-240v~/50Hz
Max Low Pressure	2.1MPa
Max High Pressure	4.2MPa
Net Weight	24kg
Moisture Removal(30°C RH80%)	1.5L/h
Refrigerant	R410A,430g
Product Dimensions	(H)700mm (W)420mm (D)310mm

Specifications are subject to change without prior notice.
If there is any inconsistency or ambiguity between the English version and the Chinese version, the Chinese version shall prevail. Refer to www.germanpool.com for the most up-to-date version of the Operating Instructions.

Environment & Recycling

Important information for correct disposal of the product in accordance with EC Directive 2012/19/EU.

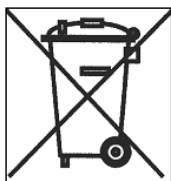

At the end of its working life, the product must not be disposed of as urban waste. It must be taken to a special local authority differentiated waste collection centre or to a dealer providing this service. Disposing of a household appliance separately avoids possible negative consequences for the environment and health deriving from inappropriate disposal and enables the constituent materials to be recovered to obtain significant savings in energy and resources. As a reminder of the need to dispose of household appliances separately, the product is marked with a crossed-out wheeled dustbin.

目錄

安全守則	28
產品結構	30
安裝說明	31
操作說明	34
清潔與保養	46
常見故障及處理	47
技術規格	49
環境與回收	49
保用條款	51

安全守則

- 本產品並不適宜身體或心智殘障、缺乏經驗或知識的人士（包括兒童）操作，除非該人士得到負責保障其安全的人士的監管或指引。
- 應監管兒童，確保他們不玩弄本機。
- 本產品可由8歲及以上年齡的兒童以及肢體不健全、感覺或精神上有障礙或缺乏相關經驗和知識的人士使用，但前提是有人對他們使用本產品進行監督或指導，以確保他們安全使用，並且讓他們明白相關的危害。
- 不得讓兒童玩耍本產品。
- 不要讓兒童在無人監督的情況下進行清潔和保養。
- 將本機及其電線放在8歲以下兒童接觸不到的地方。
- 維修期間和更換部件時，請切斷本機電源。
- 警告：連接接線端子之前，必須斷開所有電源電路。
- 如果電源線損壞，為了避免危險，必須由製造商、其維修部或類似部門的專業人員更換。
- 清潔和保養之前，請切斷電源。
- 不得將本機安裝在洗衣房。
- 請勿將本機用於本說明書中所述之外的功能。
- 如果電源線磨損或損壞，則只能由合格的維修技術人員使用原裝替換部件更換電源線。
- 確保插頭牢固並完全插入插座。否則可能導致觸電或火災危險。
- 請勿與其他電器共用一個插座，否則可能會導致觸電危險。
- 請勿拆解或改裝本機或電源線，否則可能會導致觸電或火災。其他所有維修請聯繫合格的技術人員。
- 請勿將電源線或本機放在加熱器、散熱器或其他熱源附近。否則可能會導致觸電或火災危險。
- 本機配備有接地線連接到接地引腳或接地片的電源線。插頭必須插入已正確安裝和接地的插座。任何情況下，切勿切斷或移除此插頭上的接地引腳或接地片。
- 機器的使用及儲存應防止冷凝水、濺水等，避免受潮。如果發生這種情況，請立即拔下插頭。
- 使用過程中，請始終將本機以垂直位置移動並放置在穩定的水平表面上。如果本機移動時側置，請豎立放置本機，並保持6小時不接電源。
- 請始終使用控制面板上的開關關閉本機及遙控器，並且請勿通過插拔電源線來啟動或停止運行。否則可能會導致觸電危險。
- 請勿用濕手按壓控制面板上的按鈕。
- 請勿使用危險化學品清潔或接觸本機。僅可使用軟布清潔本機，以防損壞表面光潔度。請勿使用蠟、稀釋劑或強力清潔劑。請勿在有酒精、殺蟲劑、汽油等易燃環境中使用本機。
- 應監督幼兒，確保他們不玩耍、操作或攀爬本機。

安全守則

- 如果產品發出異響或發出煙霧或異味，請立即拔下電源插頭。
- 請勿用水清潔本機。水會進入本機並損壞絕緣體，造成電擊危險。如果水進入本機，請立即拔下電源插頭並聯繫客戶服務中心。
- 應由兩個人或以上來搬運和安裝本機。
- 使用前務必從包裝中取出所有附件。
- 為免割傷，請在拆卸和重新安裝濾網時避免接觸到本機的金屬部件。否則可能會導致人身傷害。
- 請勿堵塞本機的進風口或出風口。氣流減少將導致性能下降，並可能損壞本機。
- 插拔電源插頭時，務必抓住插頭。切勿通過拉拽電源線拔出電源插頭。否則可能會導致電擊和損壞本機。
- 將本機安裝在堅固的水平地面上，能夠承受高達110磅（50公斤）的重量。將本機安裝在不堅固或不平的地面上，可能會導致財產損失和人身傷害。
- 關閉房間的所有門窗，以達最佳效果。
- 在特定高濕度環境下（>RH80%），機器運行過程中，出風口位置出現凝水，屬於正常現象。如想減少凝水，請將出風角度設置為最大，風速最大，並適當調高設定溫度。

重要 – 接地方法

本產品出廠時配有帶三腳接地插頭的電源線。必須根據國家電氣規範和當地相關法規和條例將其插入配套的接地插座中。如果電路沒有接地插座，則客戶有責任和義務根據國家電氣規範和當地相關法規和條例更換現有插座。任何情況下，都不應切割或拆除第三根接地腳。如有損壞跡象，切勿使用電源線、插頭及本機。請勿使用延長線使用本機，除非該延長線已經由合資格的電氣供應商進行檢查和測試。接地插頭連接不當可能導致火災，電擊和/或相關人員受傷。如懷疑本機是否正確接地，請諮詢合資格的服務商。

電氣連接

將本機接通電源前，請檢查：

- 主電源與本機背面銘牌上標示的值相符；
- 電源插座及電路適用於本機；
- 電源插座和本機電源插頭匹配。如果情況並非如此，請更換插頭；
- 電源插座充分接地。不遵守這些重要安全說明造成的一切後果，製造商概不負責。

產品結構

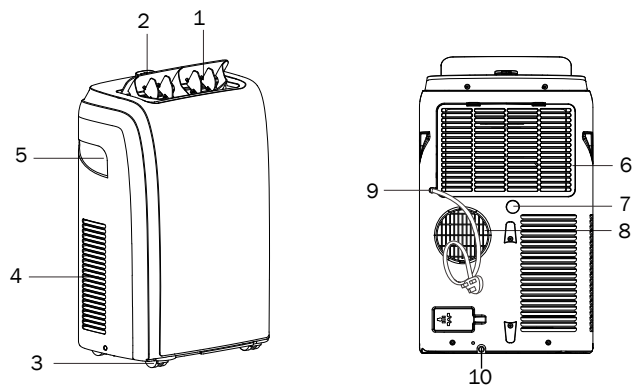

- | | |
|---------|-------------|
| 1. 出風口 | 6. 濾網 |
| 2. 控制面板 | 7. 排水口 (除濕) |
| 3. 腳輪 | 8. 排風管外殼 |
| 4. 進風口 | 9. 電源線 |
| 5. 把手 | 10. 排水孔 |

配件

部件	部件名稱	數量
	排風管 排風管接頭 排風管外接頭	1套
	窗戶密封板組件	1套
	遙控器 電池	1套
	排水管	1套

注意：本說明書中的所有插圖僅用於說明目的。實物可能稍有不同。

安裝說明

排出熱氣

在製冷模式下，本機必須放置在靠近窗戶或開口的位置，以便將排出的熱氣吹出外面。首先，將本機安放在平坦的地面上，確保本機周圍至少有12英寸（30厘米）的空隙，並且附近有單路插座電源。

1. 延伸排風管一側（圖1）並擰緊排風管接頭（圖2）。
2. 延伸排風管另一側並將其擰入排風管外接頭（圖3）。
3. 將排風管接頭安裝到機器上（圖4）。
4. 將排風管外接頭裝入窗戶密封板組件並密封。（圖5和6）。

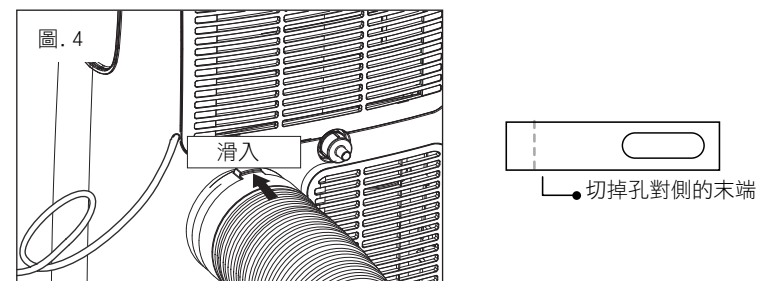
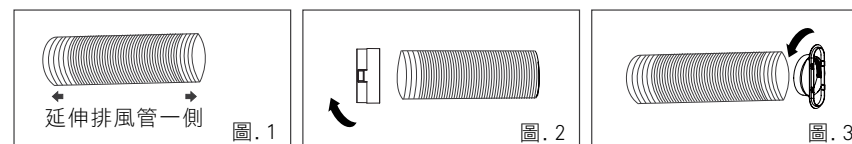

安裝說明

隨機窗戶密封板元件適用於大多數標準垂直和水平的窗口，但是，對於某些窗口類型，您可能需要修改安裝過程。窗戶密封板元件可以用螺絲固定。

注意：如果窗口的開口小於窗戶密封板元件的最小長度，請切掉窗戶密封板組件無孔側的末端，使其足夠短以適合窗口開口。切勿切掉窗戶密封板組件中的孔。



圖.5



圖.6

安裝說明

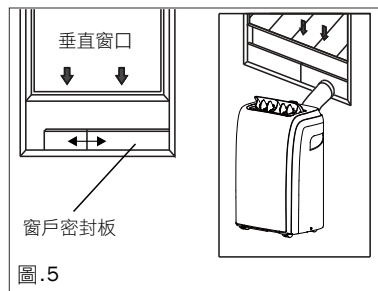
安裝窗戶密封板組件

1：零件：

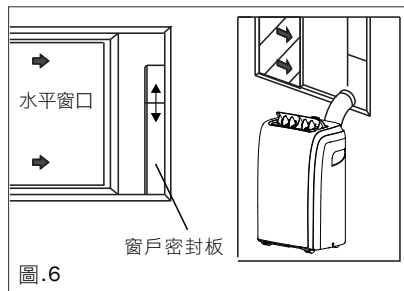
A) 密封板

B) 帶孔板

C) 無孔板（或許另購）

D) 用螺絲將窗戶密封板組件擰緊到位

2：組裝：

將B板和C板滑入A板，並將其長度調整為窗戶寬度。各窗戶大小各不相同。調整窗戶寬度時，確保測量時窗戶密封元件沒有縫隙和/或氣袋。

3：將螺絲擰入與窗戶所需寬度相對應的孔中，以確保安裝後窗戶密封板組件沒有間隙或氣袋。

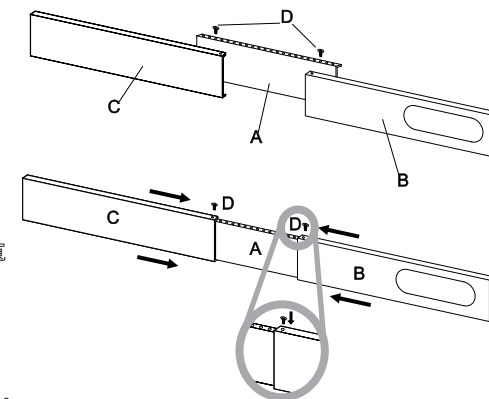

安裝位置

· 本機應放置在堅固的平面上，以儘量減少噪音和振動。為了安全和牢固放置，請將本機放置在足夠堅固的平穩水平地板上以支撐本機。

· 本機有腳輪用以輔助放置，但只能在平滑的平面上滾動。在地毯上滾動時要小心。在木地板上滾動時要小心並保護地板。不要將本機滾過物體。

· 本機必須放置能夠連接到適當的額定接地插座的地方。

· 切勿在本機的進氣口和出氣口周圍放置任何物品。

· 為了高效的空調性能，空調與牆之間要留出至少30厘米的距離。

· 排風管可以延長，但長度最好保持在所需最短長度。還要確保排風管沒有任何急轉彎或凹陷。

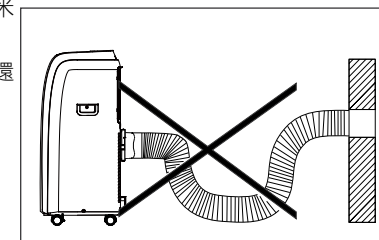
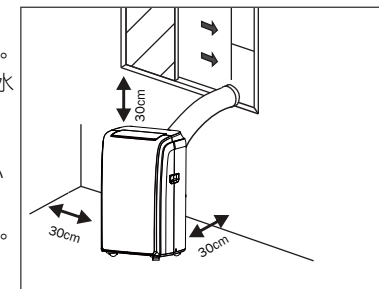

操作說明

顯示屏

- 1 製冷圖示
- 2 風速指示燈
- 3 定時圖示
- 4 溫度圖示
- 5 溫度指示燈

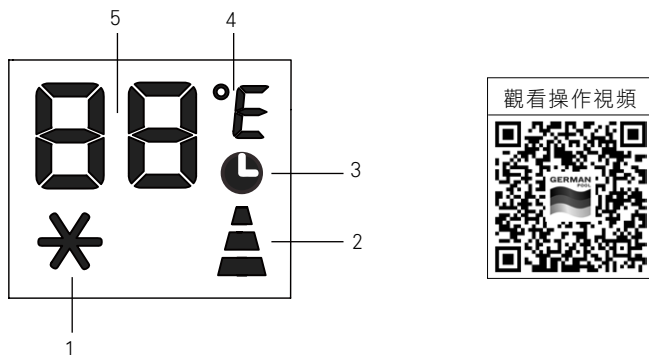

主機面板操作

控制面板位於機器頂部，您無需遙控器即可操控部分功能，但要充分發揮其潛力，您必須使用遙控器。

- 1 電源開關鍵
- 2 模式鍵
- 3 送風鍵
- 4 上調鍵
- 5 下調鍵

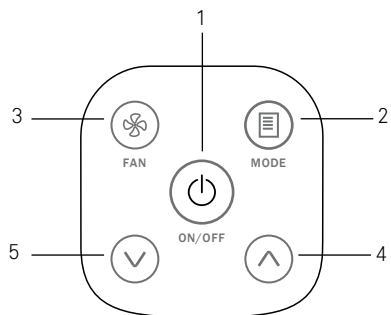

開機

插入電源插座，進入待機狀態。

按下  鍵開啟本機。顯示上次關閉時最後所啟動的功能。





警告

切勿通過拔下電源插頭關閉本機。務必先按下  鍵，等待幾分鐘再拔下電源插頭，以便本機運行一個檢查週期來核實操作。

操作說明

製冷模式

適合悶熱而潮濕的天氣，房間需要降溫和除濕時。正確設置此模式：

- 連續按下  模式鍵直至此  圖示出現。
- 按  上調鍵或  下調鍵選擇目標溫度18°C–32°C (64°F–90°F)，直至顯示相應的溫度值。
- 按下  送風鍵選擇所需的風速。

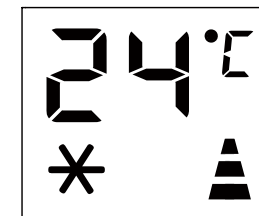

注意：為保護壓縮機，製冷模式下壓縮機可能延遲啟動製冷。

三段風速可選：

 高速：設定最高風速



 中速：降低噪音水平但仍保持良好的舒適度

 低速：靜音運作

夏季房間最適宜的溫度在24°C至27°C (75°F至81°F) 之間。但是，建議您不要將溫度設定得遠低於室外溫度。風扇各速度在風速模式下差異更明顯，但在製冷模式下可能受影響。

送風模式

該模式下，無須連接排風管。

- 按下  鍵直到  指示燈亮起。
- 按  鍵選擇所需的風速。

三檔風速可選：

 高速：設定最高風速

 中速：可降低噪音水平但仍保持良好舒適度

 低速：靜音運作

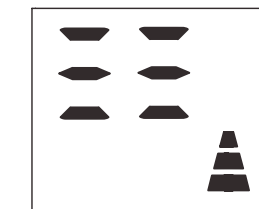

操作說明



除濕模式

此功能可有效保持理想的室內濕度（春季和秋季、潮濕房間、雨季等）。
除濕模式下，應依照製冷模式要求運作，並連接排水管，以便將濕氣排出。
正確設置此模式：

- 按 按鈕直到 **dh** 指示燈亮起
- 按 鍵選擇所需的風速

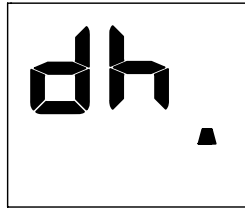

注意：除濕模式下不可調節溫度，只可調節風速大小。

注意：當室內溫度 $\leq 16^{\circ}\text{C}$ 時，壓縮機無法開啟，不能運行除濕功能。

三檔風速可選：



高速：為達到最佳的除濕效果



中速：可降低噪音水平但仍具有更好的除濕效果



低速：靜音運作但除濕效果相對較弱

除濕模式下，需要另購的橡膠軟管或排水管（隨機附送）以便排出冷凝水。

請按照以下步驟操作：

- 擰下連續排水的排水蓋（圖7）。
- 將橡膠軟管（另購）的一端或排水管（隨機附送）連接到排水口，然後將另一端放入比本設備低的接水盤（圖8）。

圖7



圖8



橡膠軟管

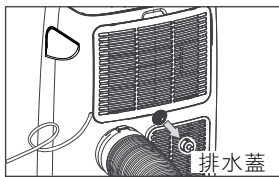
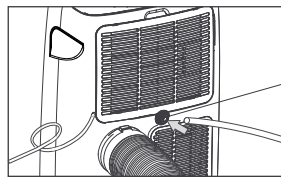

操作說明

注意：

- 如果空調此前以製冷模式運行，取下排水蓋後冷凝水可能會流出。當您想要取下橡膠軟管時，請準備一個接水盤（未提供），以從排水口收集冷凝水。
- 請確保排水管的高度和排水管位於排水口之下，否則可能導致無法連續排水。
- 製冷模式下，不建議採用連續排水。可取下排水管並蓋上排水蓋，以達到最佳效果。

圖9



圖10



溫度單位的切換

當空調處於待機狀態時，長按 鍵20秒，即可更改溫度單位。

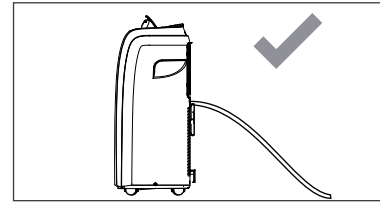
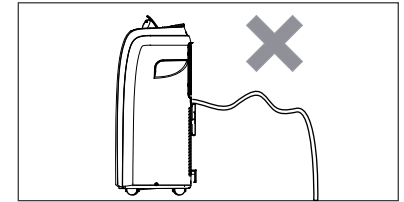
例如：

更改前，製冷模式下，液晶屏顯示如圖11。

更改後，製冷模式下，液晶屏顯示如圖12。



圖11



圖12

操作說明

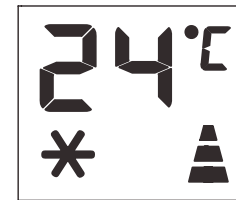
遙控器操作

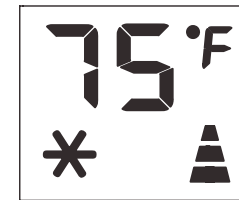
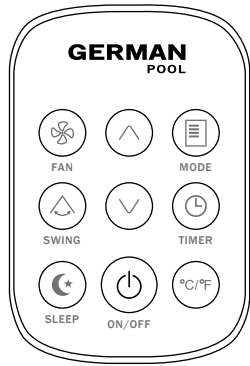

- 送風鍵
- 擺風鍵
- 睡眠模式鍵
- 上調鍵
- 下調鍵
- 電源開關鍵
- 模式鍵
- 定時鍵
- °C/°F 單位切換鍵

- ✓ 將遙控器指向空調上的接收器。
- ✓ 空調與遙控器的距離不能超過7米（遙控器和空調間沒有障礙物）。
- ✓ 必須妥善保管遙控器。請勿拋落或暴露在陽光下直射或放置於熱源下。如果遙控器不工作，請嘗試取出先電池隨後放回。

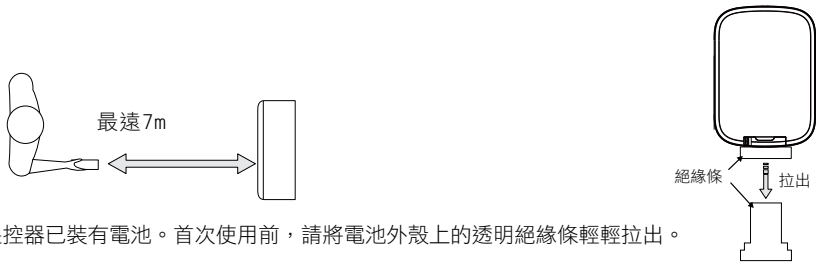

遙控器已裝有電池。首次使用前，請將電池外殼上的透明絕緣條輕輕拉出。

更換電池

請按照以下步驟操作：

- 1) 按下電池蓋針，打開電池蓋；
- 2) 更換電池並將電池蓋裝回遙控器。

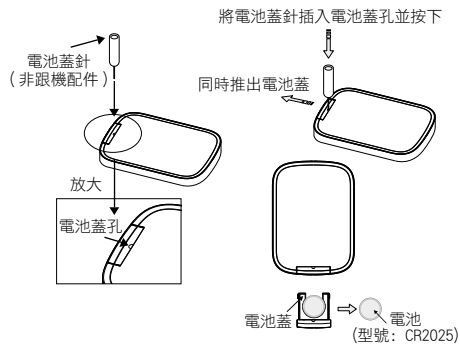

操作說明

製冷模式

適合悶熱而潮濕的天氣，房間需要降溫和除濕時。

正確設置此模式：

- 連續按下 (MODE) 模式鍵直至此 * 圖示出現。
- 按 ^ 上調鍵或 v 下調鍵選擇目標溫度18°C-32°C (64°F-90°F)，直至顯示相應的溫度值。
- 按下 (FAN) 送風鍵選擇所需的風速。

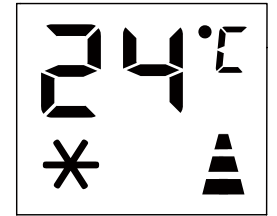

注意：為保護壓縮機，製冷模式下壓縮機可能延遲啟動製冷。

三段風速可選：

- ▲ 高速：設定最高風速
- ▲ 中速：降低噪音水平但仍保持良好的舒適度
- ▲ 低速：靜音運作

夏季房間最適宜的溫度在24°C至27°C (75°F至81°F) 之間。但是，建議您不要將溫度設定得遠低於室外溫度。風扇各速度在風速模式下差異更明顯，但在製冷模式下可能受影響。

送風模式

該模式下，無須連接排風管。

- 按下 (MODE) 鍵直到 指示燈亮起。
- 按 (FAN) 鍵選擇所需的風速。

三檔風速可選：

- ▲ 高速：設定最高風速
- ▲ 中速：可降低噪音水平但仍保持良好舒適度
- ▲ 低速：靜音運作

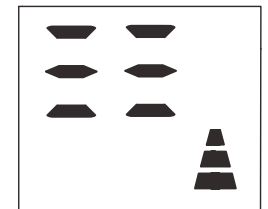

操作說明



除濕模式

此功能可有效保持理想的室內濕度（春季和秋季、潮濕房間、雨季等）。
除濕模式下，應依照製冷模式要求運作，並連接排水管，以便將濕氣排出。
正確設置此模式：

- 按 按鈕直到 **dh** 指示燈亮起。
- 按 鍵選擇所需的風速。

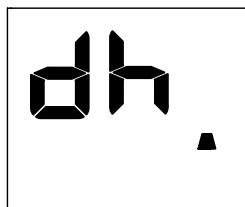

注意：除濕模式下不可調節溫度，只可調節風速大小。

注意：當室內溫度 $\leq 16^{\circ}\text{C}$ 時，壓縮機無法開啟，不能運行除濕功能。

三檔風速可選：



高速：為達到最佳的除濕效果



中速：可降低噪音水平但仍具有更好的除濕效果



低速：靜音運作但除濕效果相對較弱

除濕模式下，需要另購的橡膠軟管或排水管（隨機附送）以便排出冷凝水。

請按照以下步驟操作：

- 擰下連續排水的排水蓋（圖13）。
- 將橡膠軟管（另購）的一端或排水管（隨機附送）連接到排水口，然後將另一端放入比本設備低的接水盤（圖14）。

圖13



圖14



橡膠軟管

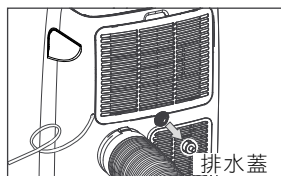
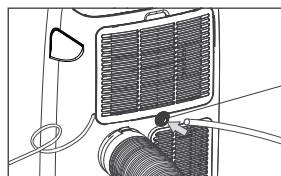
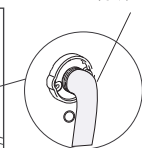

排水蓋

操作說明

注意：

- 如果空調此前以製冷模式運行，取下排水蓋後冷凝水可能會流出。當您想要取下橡膠軟管時，請準備一個接水盤（未提供），以從排水口收集冷凝水。
- 請確保排水管的高度和排水管位於排水口之下，否則可能導致無法連續排水。
- 製冷模式下，不建議採用連續排水。可取下排水管並蓋上排水蓋，以達到最佳效果。

圖15



圖16



擺風功能

此功能可設定上/下搖擺送風。

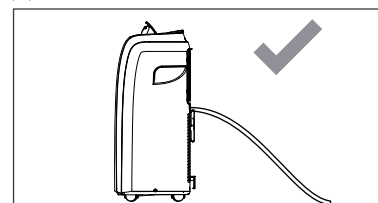
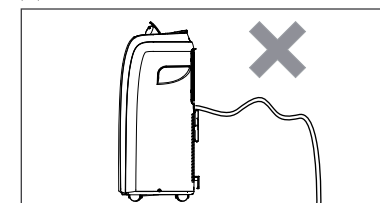
要正確設置此功能：

- 如上所述選擇運行模式（製冷，除濕，送風）。
- 多次按下 按鈕，導風板將停止不同位置或連續擺動。

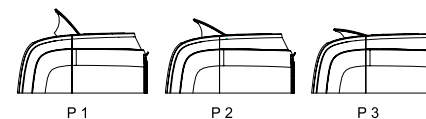
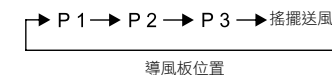

操作說明

睡眠模式

此功能適用於夜晚，因為空調會逐漸減緩運作。

要正確設置此功能：

- 如上所述選擇製冷模式。

按下  鍵。設備以此前設定的模式運行。

- 選擇睡眠功能時，液晶屏會降低亮度。

睡眠功能可將房間保持在最佳溫度，保持室內溫度或濕度的恒定。

風速維持低速，並通過逐漸調整室內溫度和濕度，以確保最舒適體驗。

製冷模式下，前2小時以每小時對預設溫度增加1°C (1°F)。而這個新設定的溫度將在接下來的6個小時內保持不變。然後，空調將自動關閉。

睡眠功能運作時，可隨時通過按下“睡眠”“模式”或“風扇”按鈕，以取消睡眠功能。



注意:送風或除濕模式下，不能設置睡眠功能。

溫度單位的切換

當設備處於待機狀態時，按下°C/°F 鍵，即可更改溫度單位。

例如：

更改前，製冷模式下，液晶屏顯示如圖17。

更改後，製冷模式下，液晶屏顯示如圖18。



圖17



圖18

操作說明

定時功能

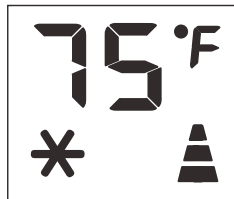

本設備可定時啟動或關機，以避免能源浪費。

定時啟動

- 啟動空調，選擇所需模式如製冷功能，24°C，高風速。隨後關閉空調。

- 按下  鍵，液晶屏顯示1-24小時，*    指示燈一同閃爍（如圖19）

- 按鍵數次以設定時間，5秒後計時器啟動，液晶屏上只有  指示燈常亮（如圖20）

- 再一次按下  或  鍵則取消定時， 指示燈熄滅。



圖19





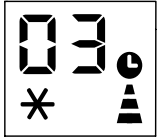

圖20

定時關機

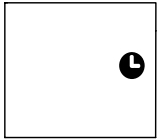
- 空調運行時按  鍵，液晶屏顯示時間，所有指示燈閃爍（如圖21）

- 按鍵數次以設定時間，5秒後計時器啟動，液晶屏上只有  指示燈常亮（如圖22）

- 再一次按下  或  鍵則取消定時， 指示燈熄滅。



圖21



圖22

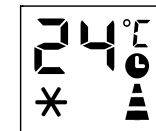

圖23

操作說明

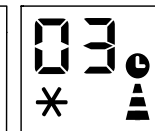
正確使用提示

為了達到最佳使用效果，請遵循以下建議：

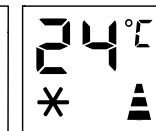
- 關閉房間中的門窗（圖24）。當以半永久安裝空調時，門應稍稍打開（小至1厘米）以保證良好的通風；
- 關閉窗簾或百葉窗，使房間避免直接暴露在陽光下，使空調的運行更經濟節能（圖25）；
- 絕對不要在空調上放置任何的物體；
- 請勿阻塞進氣口和出氣口（圖26）。請勿堵住格柵。
- 確保房間內沒有熱源；
- 切勿在潮濕的房間（例如洗衣房）使用本產品。
- 切勿在戶外使用本機。
- 確保電器放在水平面上，必要時可於前輪下方放置腳輪鎖。

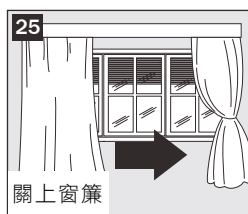
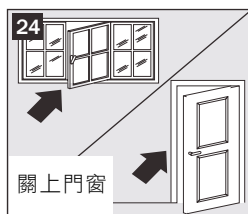

排水方法

當設備內部冷凝水過多時，設備停止運行並顯示“FL”（如自診斷中所述的滿水提示）。

這表明需要按照以下程式排水：

手動排水（圖27）

濕度較高地區需要排水：

1. 先關閉機器電源，拔出電源插頭。
2. 將盛水的容器（須自備）放在機體後側排水蓋的下方。見下圖。
3. 拔下水塞。
4. 水自動流入盛水的容器裡（須自備）。
5. 當水放完後，請立即向擰緊水塞。
6. 啟動空調。

操作說明

連續排水（圖28）

使用除濕機模式時，建議使用連續排水。

1. 從電源上拔下電源插頭。
2. 拔下水塞。在進行此操作時，有些殘留的水可能會溢出，因此請準備接水盤（須自備）。
3. 連接排水軟管（1/2”：或12.7mm，或需另購）。
4. 水通過軟管連續排入地漏或水桶。
5. 啟動空調。

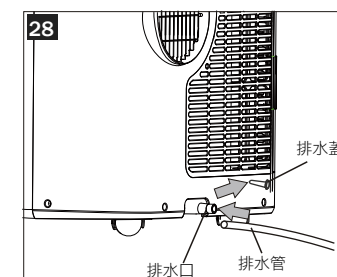
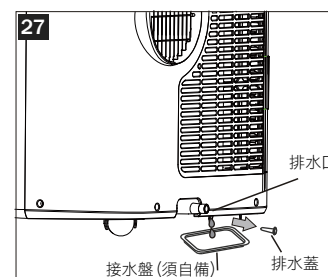

注意

請確保排水管應低於排水口，否則水箱可能不會排水。（圖29和圖30）

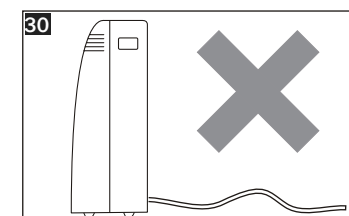
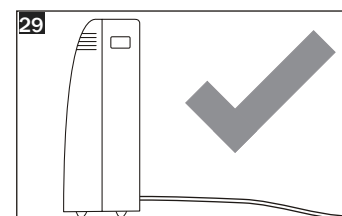

清潔與保養

在清潔或維護之前，按下控制面板或遙控器上的  電源開關鍵關閉空調，幾分鐘後拔下電源插頭。

清潔外殼

應使用擰乾的抹布清潔空調，然後用乾布擦乾。

- 避免危險，切勿水洗空調。
- 切勿使用汽油，酒精或溶液清潔。
- 切勿噴灑殺蟲水或類似溶液。



清潔過濾網

為了讓您的設備高效運行，應該每週清潔一次濾網。

濾網可以取出，如圖下圖。

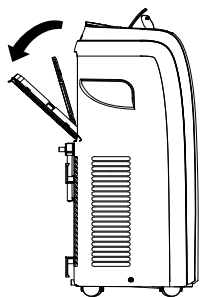

使用吸塵機清除濾網上的積塵。如果非常髒，請將濾網浸入溫水中並沖洗數次。水溫不得超過40°C (104°F)。清洗後，待濾網變乾，然後將進氣格柵安裝到設備上。

啟動或長時間不用設備時

啟動空調前

確保電源線和插頭沒有損壞，並且接地連接有效。

並已根據安裝說明進行準確安裝。

長時間不使用本機時：

旋開排水蓋，拔出水塞(如圖31)

排出接水盤中的水，隨後擰回水塞。

清洗濾網，待濾網變乾後重新裝上。

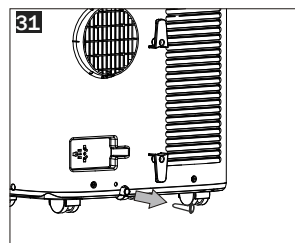

常見故障及處理

自我診斷

空調有自我診斷系統以識別設備故障。故障代碼會顯示於液晶屏上。

若顯示	我應該怎樣做？
 低溫 (防止結霜)	本空調配有防霜裝置，以避免過度結霜。 除霜完成後，設備將自動重新開機。
 探頭故障 (感應探頭損壞)	如果顯示此代碼，請聯繫客戶服務中心。
 水滿 (水箱裝滿)	按照“長期不使用設備”中的說明清空內部水箱。

常見故障及處理

問題	原因	解決方法
空調不工作	<ul style="list-style-type: none"> 沒有電 插頭未插好 安全裝置跳閘 	<ul style="list-style-type: none"> 稍作等候 插入電源 靜候30分鐘，若故障持續請聯繫客戶服務中心；
空調只能在短時間內工作	<ul style="list-style-type: none"> 排風軟管彎曲 出風口被堵塞，空氣無法排出 	<ul style="list-style-type: none"> 正確定位排風軟管，避免軟管彎曲折疊 檢查並清除阻塞空氣排放的障礙物
空調工作但不製冷	<ul style="list-style-type: none"> 窗戶，門或窗簾打開 房間內有熱源（烤箱，吹風機等） 與空調側相連的排風管鬆開 空調技術規格不適合其所在的空間 	<ul style="list-style-type: none"> 關閉門窗和窗簾，請按照上述“正確使用提示”操作 消除熱源 將排風管重新安裝在空調上
運行期間有異味產生	<ul style="list-style-type: none"> 過濾網堵塞 	<ul style="list-style-type: none"> 清潔過濾網
在重新開機設備後，約三分鐘內設備不啟動	<ul style="list-style-type: none"> 壓縮機的保護裝置阻止設備重新開機，直至距離上次啟動間隔3分鐘後方可重新啟動； 	<ul style="list-style-type: none"> 稍作等候，屬正常現象
液晶屏顯示 LE/PF/FE	<ul style="list-style-type: none"> 設備具有自我診斷系統，可自行識別各種故障 	<ul style="list-style-type: none"> 見自我診斷章節內容

技術規格

型號	PAC-208
額定功率	8,000 BTU/hr
製冷能力	1,010W
額定電壓/頻率	220-240V~/50Hz
最大低壓	2.1MPa
最大高壓	4.2MPa
淨重	24kg
抽濕量 (30°C RH80%)	1.5L/h
雪種	R410A,430g
機身尺寸	(H)700mm (W)420mm (D)310mm

產品規格及設計如有變更，恕不另行通知。
中英文版本如有出入，一概以中文版為準。
本產品使用說明書以 www.germanpool.com 網上版為最新版本。

環境與回收

根據EC指令2012/19 / EU，正確處理本產品的重要資訊。

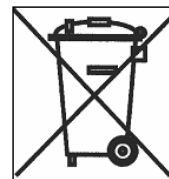

使用壽命結束時，本產品不得作為城市垃圾處理。必須將其拿到當地政府特定的廢物分類回收中心或提供此服務的經銷商。單獨處理家用電器避免由於不正確處理產品而帶來的對環境和人體健康的危害，並且使得組成材料能夠被回收，從而顯著節省能源、資源。產品上有打叉的輪式垃圾桶的標識，用以提示家用電器需單獨處理。

保用條款

此保用提供德國寶產品之機件在正常使用下壹年保用(自購買日起計算)。

Warranty Terms & Conditions

Under normal operations, the product will gurantee a 1-year full warranty provided by German Pool (effective from the date of purchase).

* 貴戶須在購機十天內，以下列其中一種方式向本公司登記資料，保用手續方正式生效：

1) 填妥本公司網頁內之保用登記表格

www.germanpool.com/warranty

2) 填妥保用登記卡，郵寄至本公司。



* This warranty is not valid until customer registration information is received by our Service Centre within 10 days of purchase via one of the following means:

1) Visit our website and register online:

www.germanpool.com/warranty

2) Complete all the fields on the attached Warranty Card and mail it back to our Customer Service Centre.



另請填妥以下表格並與正本發票一併保存，以便維修時核對資料。用戶提供之所有資料必須正確無誤，否則免費保用將會無效。 Please fill out the form below. This information and the original purchase invoice will be required for any repairs. Warranty will be invalidated if information provided is found to be inaccurate.

型號 Model No. : **PAC-208**

機身號碼 Serial No. : _____ 發票號碼 Invoice No. : _____

購買商號 Purchased From : _____ 購買日期 Purchase Date : _____

1. 未能出示購買發票正本者，將不獲免費維修服務。
2. 用戶應依照說明書的指示操作。本保用並不包括：
 - 上門安裝、檢驗、維修或更換零件之人工以及一切運輸費用；
 - 因天然與人為意外造成的損壞 (包括運輸及其他)；
 - 電源接合不當、不依說明書而錯誤或疏忽使用本機所引致之損壞。
3. 於下列情況下，用戶之保用資格將被取消：
 - 購買發票有任何非認可之刪改；
 - 產品被用作商業或工業用途；
 - 產品經非認可之技術人員改裝或加裝任何配件；
 - 機身編號被擅自塗改、破壞或刪除。
4. 總代理有權選擇維修或更換配件或其損壞部份。
5. 產品一經被轉讓，其保用即被視作無效。

1. Customer who fails to present original purchase invoice will not be eligible for free warranty service.
2. Customer should always follow the operating instructions. This warranty does not apply to:
 - labour costs for on-site installation, check-up, repair, replacement of parts and other transportation costs;
 - damages caused by accidents of any kind (including material transfer and others);
 - operating failures resulting from applying incorrect voltage, improper usage, and unauthorized installations or repairs.
3. This warranty is invalid if:
 - the purchase invoice is modified by an unauthorized party;
 - the product is used for any commercial or industrial purposes;
 - the product is repaired or modified by unauthorized personnel, or unauthorized parts are installed;
 - the serial number is modified, damaged or removed from the product.
4. German Pool will, at its discretion, repair or replace any defective part.
5. This warranty will be void if there is any transfer of ownership from the original purchaser.

客戶服務及維修中心

中國香港

九龍灣啟興道1-3號

九龍貨倉10樓

電話：+852 2333 6249

傳真：+852 2356 9798

電郵：repairs@germanpool.com

中國澳門

澳門俾利喇街145號

寶豐工業大廈3樓

電話：+853 2875 2699

傳真：+853 2875 2661

Customer Service & Repair Centre

Hong Kong, China

10/F, Kowloon Godown

1-3 Kai Hing Road, Kowloon Bay,

Kowloon, Hong Kong

Tel : +852 2333 6249

Fax : +852 2356 9798

Email : repairs@germanpool.com

Macau, China

3/F, Edificio Industrial Pou Fung,

145 Rua de Francisco Xavier Pereira,

Macau

Tel : +853 2875 2699

Fax : +853 2875 2661

German Pool (Hong Kong) Limited

Hong Kong, China

Room 113, Newport Centre Phase II, 116 Ma Tau
Kok Road, Tokwawan, Kowloon, Hong Kong.
Tel: +852 2773 2888
Fax: +852 2765 8215

Mainland China

8th, Xinxiang Road, Wusha Industrial Park,
Daliang, Shunde, Foshan, Guangdong
Tel: +86 757 2980 8308
Fax: +86 757 2980 8318

Macau, China

3/F, Edifício Industrial Pou Fung,
145 Rua de Francisco Xavier Pereira, Macau
Tel: +853 2875 2699
Fax: +853 2875 2661



香港《S MARK》
安全認證



中國標榜/家電行業
十大影響力品牌



CEO非凡品牌大賞



香港優質商標



香港工商業獎



2007
最具潛質
創星品牌企業獎



香港中小企業
最佳拍檔大獎



香港消費者推祟品牌



香港《Q標》
優質服務證書



香港名牌十年成就獎
HONG KONG TOP BRAND TEN YEAR
ACHIEVEMENT AWARD

© All rights reserved. Copying, reproducing or using the contents of this manual is not allowed without prior authorization from German Pool, violators will be prosecuted.