

GERMAN  
POOL



德國寶

嵌入式消毒碗櫃  
Built-In Ozone Dish Sterilizer

DSR-310BK

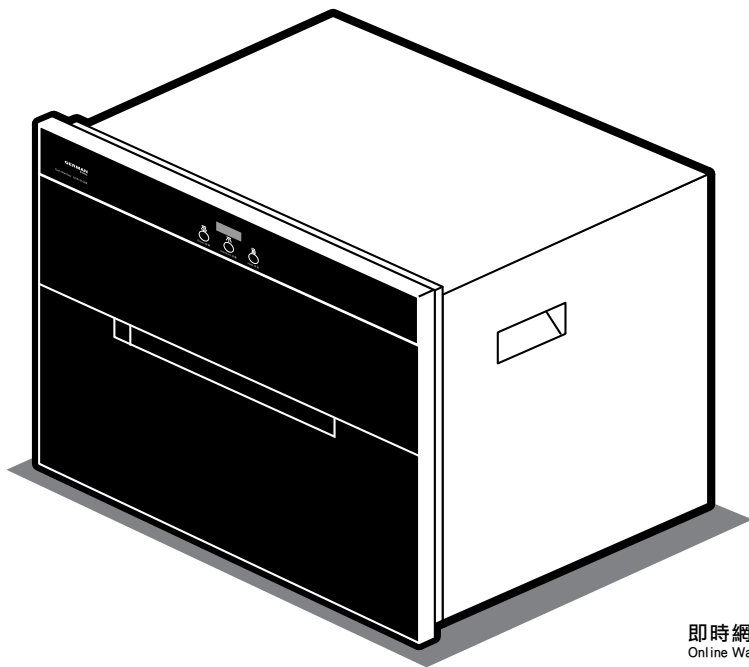

即時網上登記保用  
Online Warranty Registration



在使用之前請詳細閱讀「使用說明書」及「保用條款」，並妥為保存。  
Please read these instructions and warranty information carefully  
before use and keep them handy for future reference.

使用說明書 USER MANUAL

請即進行保用登記!  
有關保用條款細則，請看本說明書最後一頁。

---

Please register your warranty information now!  
For Warranty Terms & Conditions,  
please refer to the last page of this user manual.

## 目錄

產品介紹	4
安裝須知	5
安裝說明	6
產品結構	7
使用說明	8
安全注意事項	10
清潔與保養	11
技術規格	11
電器原理圖	12
保用條款	23

# 產品介紹

## 產品說明

本產品採用紫外線和臭氧對餐具進行殺菌（可有效殺滅化膿性球菌、腸道致病菌），利用紅外線進行烘乾，殺菌效果可達到GB17988-2008規定的二星級標準。

## 使用範圍

適用於家庭餐具的消毒。

## 隨機附件（裝箱單）

消毒碗櫃	木螺釘	說明書	保用登記證
1台	4隻	1本	1份

# 安裝須知

使用前請仔細閱讀本說明書。本說明書會向您詳細介紹本機的安裝、使用、維護保養以及注意事項等，以便充分發揮其性能。

1. 電器安裝應委託專業人員執行。線路容量不足，施工不完善，會導致短路等意外情況。
2. 插座的額定電流不小於10A，請勿與其他家用電器共用一個插座，將插座接入帶有漏電保護裝置的線路內，以確保安全。
3. 插座應可靠接地，不得將接地線接於自來水管、煤氣管、避雷器及電話線上，防止引發意外事故。
4. 本機安裝後不應成為承受重量的工具，否則會損毀內部零件。

# 安裝說明

1. 在廚櫃安裝的位置上，按圖示尺寸設置方孔，將消毒櫃平穩嵌入，拉開抽屜，用四個木螺釘將箱體固定。
2. 消毒碗櫃可按需要設置嵌入的位置高度，但支撐消毒碗櫃底部基礎的承重能力必須大於60kg。
3. 消毒碗櫃應平穩安裝放置，確保拉動抽屜時無搖晃、抖動現象發生，合上抽屜時，應確保周邊充分密閉。

## 安裝示意圖

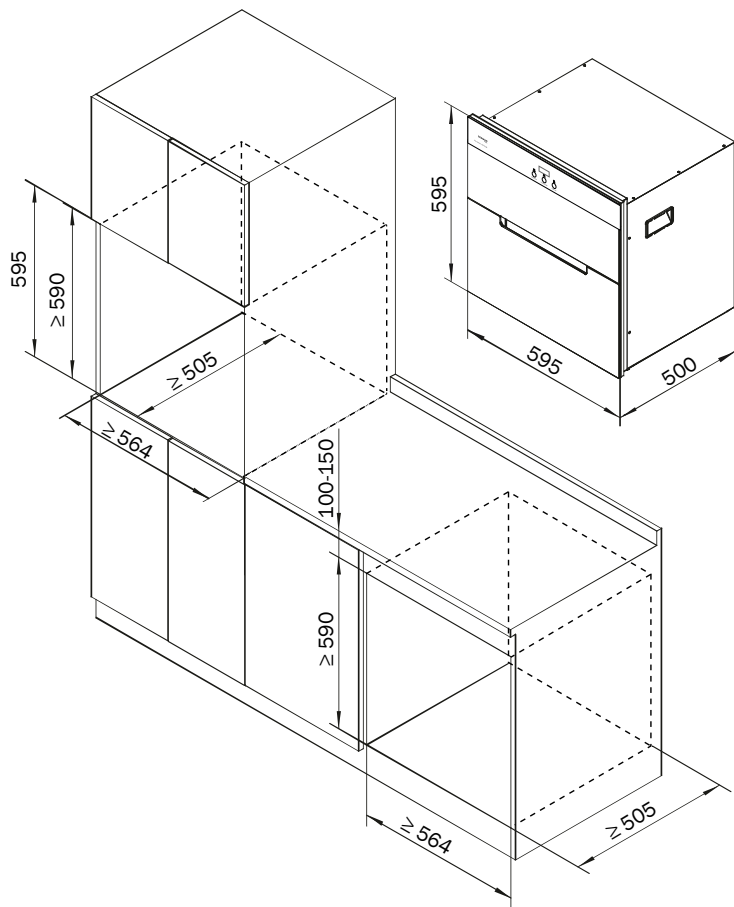

P.6

# 產品結構

## 主機

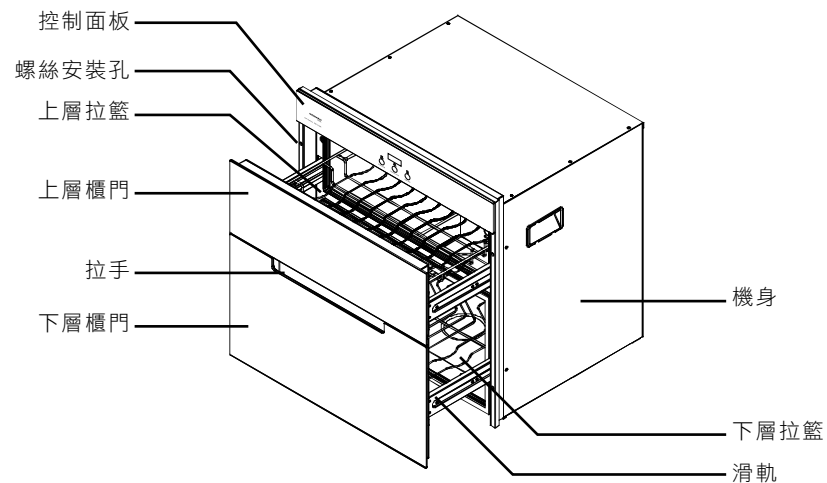

## 控制面板

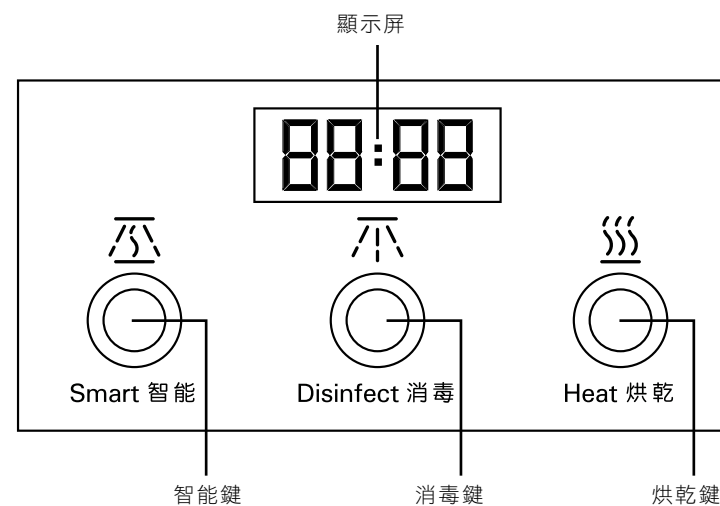

P.7

# 使用說明

## 1. 開關櫃門

手握櫃門把手，將櫃門沿水平線拉出或推入，切勿用力過猛。

## 2. 餐具放置

餐具洗淨瀝乾水後依次豎著放在碗架上，放置時不宜過密，否則影響消毒、烘乾效果。

## 3. 開門保護

當打開櫃門時，處於保護狀態，所有功能停止工作，須關上櫃門，才能重新操作。

## 4. 按鍵說明

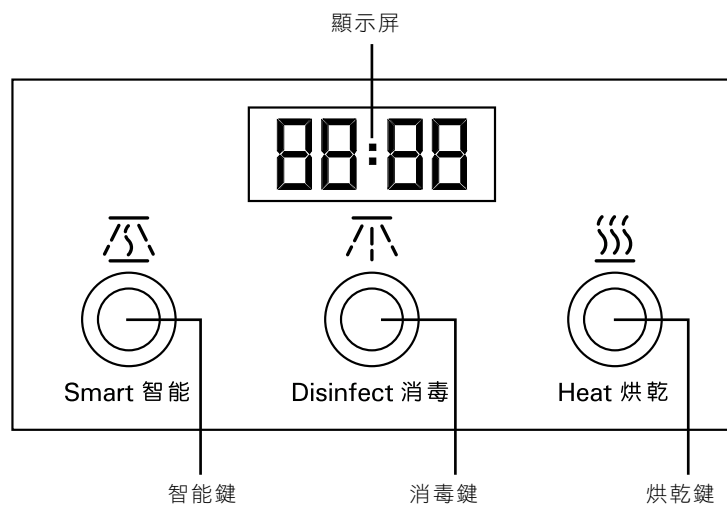

### 上電／初始化操作：

確認安裝到位，抽屜已經關閉後，可開機通電。插上電源插頭，機內發出“嘀”一聲，提示電源已接通，進入待機狀態。

# 使用說明

## 消毒功能：

待機狀態下，按一次殺消毒鍵，消毒鍵指示燈亮，時間顯示90:00，此時5秒內可進行消毒時間設置，再按一次時間顯示60:00，按第三次顯示30:00，按四次屏幕熄滅，依次循環；消毒時間設置完成後5秒內無其它操作則開始運行消毒功能，倒計時運行至00:00時消毒工作完成，同時發出“滴滴滴滴”16聲提示。

## 烘乾功能：

待機狀態下，按一次烘乾鍵，烘乾鍵指示燈亮，時間顯示90:00，此時5秒內可進行烘乾時間設置，再按一次時間顯示60:00，按第三次顯示30:00，按四次屏幕熄滅，依次循環；烘乾時間設置完成後5秒內無其它操作則開始運行烘乾功能，倒計時運行至00:00時烘乾完成，同時發出“滴滴滴滴”16聲提示。

## 智能模式：

在待機狀態下，按一次智能鍵，智能鍵指示燈亮，時間顯示60:00，5秒內無其它按鍵操作進入智能模式，倒計時運行至00:00時消毒完成，時間顯示45:00，待機至00:00，啟動烘乾功能，時間顯示60:00，倒計時運行至00:00時烘乾完成，同時發出“滴滴滴滴”16聲提示。

## 組合功能：

待機狀態下，按消毒鍵，時間設置完成後，5秒內再按烘乾鍵可組合運行烘乾功能。同理，按烘乾鍵，時間設置完成後，5秒內再按消毒鍵也可組合運行消毒功能，時間可任意選擇90、60或30分鐘。

組合功能時，先運行消毒功能，消毒停止後，待機45分鐘再運行烘乾功能，消毒和烘乾不能同時運行，消毒和烘乾指示燈同時亮起。為達到最佳效果，建議選擇90分鐘消毒和90分鐘烘乾組合。



## 安全注意事項

1. 拔出插頭時，必須手握插頭端部將其拔出，請勿用手直接拉扯電源線以拔出插頭。
2. 如電源線損壞或發生其他故障，必須由本公司或合資格的專業技術人員更換和維修。
3. 必須確保使用的電源電壓與本機銘牌指定的電壓一致，否則會對本機造成損毀。
4. 除專業維修技術人員外，不得對本機進行拆卸修理。
5. 請不要對機器噴水，否則有短路或觸電危險。
6. 請不要將漆器，耐熱性差的塑膠餐具或非食具（如毛巾、鞋子等）放入消毒碗櫃內。
7. 在使用本產品時，應將食具上的水倒淨後才能放入櫃內。
8. 在消毒（烘乾）結束20分鐘後才能打開抽屜，以免臭氧洩漏和燙傷。
9. 為防止燙傷，打開櫃門，機器會自動保護，停止工作，並非機器故障。
10. 當消毒工作程式啟動時，櫃門已上鎖，請勿強拉。
11. 必須確保電源插座的接地極有效接地。
12. 請勿讓兒童或身體虛弱的人操作使用消毒櫃，否則容易導致燙傷、觸電或其他意外發生。
13. 請勿用濕手插上或拔出電源插頭。
14. 請勿將小型物件放在筷叉網籃以外的區域，防止掉落下層。

### 警告！

1. 在使用過程中若發現臭氧洩漏或在任何角度不經過任何透光物體即可直接看到殺菌燈管發出的光線時，應馬上停止使用，並通知專業人員進行維修。
2. 若殺菌燈管損壞，必須聯繫售後服務及維修中心更換相同功率（15W）和波長（253.7nm）的殺菌燈管。
3. 關好櫃門後，才能進行殺菌或烘乾作業，否則會發生臭氧洩漏、紫外線輻射或燙傷現象。

## 清潔與保養

請根據您的使用頻率和周圍環境狀況，定期地清潔和保養消毒碗櫃。這樣能使消毒碗櫃保持良好的消毒、烘乾效果和較長的使用壽命。

- 請先停止機器的所有工作，拔出電源插頭，待機器冷卻後，再進行清潔保養工作。
  - 清潔或保養消毒碗櫃時，請戴上手套，以防在擦拭過程中手指受傷。
1. 櫃門、拉籃及內膽用沾有中性洗滌液的軟布擦去污垢，再用濕布擦去殘留的洗滌液，然後用乾布抹乾。
  2. 經常清理內膽底部積水，以免水滿外溢。
  3. 箱體外側表面的清潔不得用汽油、酒精及其它溶劑、去污粉等，否則會導致主機殼變色，損傷表面漆膜。

觀看操作視頻



## 技術規格

型號	DSR-310BK
電壓 / 頻率	220 V / 50 Hz
功率（最大）	310W
臭氧濃度 (mg/m <sup>3</sup> )	≥ 40
容量 (L)	100
淨重 (kg)	26 kg
標準承載量 (kg)	上層：6 下層：8
烘乾溫度 (°C)	≤ 75
機身尺寸 (mm)	(H)595mm X (W)595mm X (D)500mm
安裝開孔尺寸 (mm)	(H) ≥ 590mm X (W) ≥ 564 X (D) ≥ 505mm

產品規格及設計如有變更，恕不另行通知。  
中英文版本如有出入，一概以中文版為準。  
本產品使用說明書以 [www.germanpool.com](http://www.germanpool.com) 網上版為最新版本。

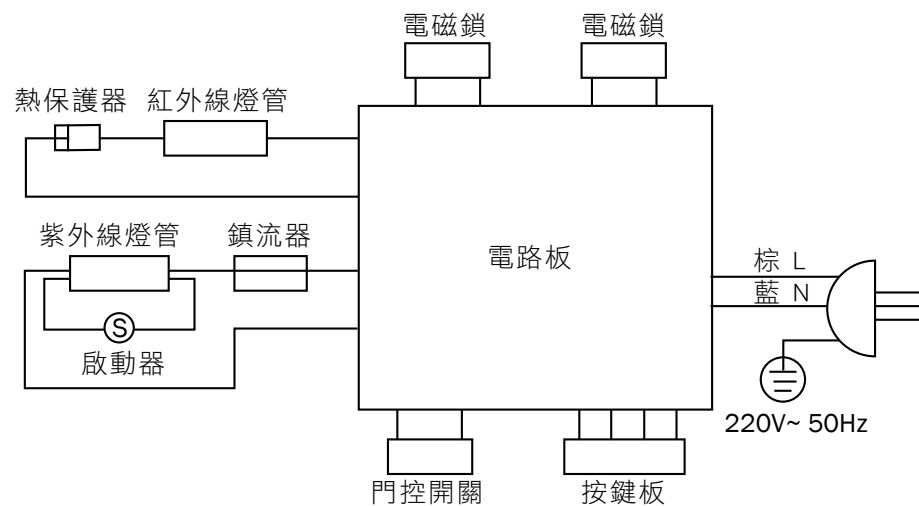

Product Summary	14
Installation Guide	15
Installation Instructions	16
Product Structure	17
Operating Instructions	18
Safety Precautions	20
Care and Maintenance	21
Technical Specifications	21
Circuit Diagram	22
Warranty Terms & Conditions	23

# Product Summary

---

## Product Overview

This product uses UV and ozone to first sterilize tableware (capable of effectively exterminating pyogenic coccus and pathogenic enterobacteriaceae), and then dry the tableware with infrared ray. Its sterilization result reaches two-star standard specified in GB17988-2008.

## Area of Application

The sterilizer is applicable to household utensils.

## Supplied Accessories (Packing List)

Dish sterilizer	Wood screw	User manual	Warranty card
1	4	1	1

# Installation Guide

---

Read this manual carefully before using the appliance. Detailed illustration on its installation, operation, maintenance and precautions will be presented in this manual to help you fully utilize its functionalities.

1. The appliance should be installed by qualified technicians. Insufficient loading and improper installation would result in short circuit or other electrical hazards.
2. To ensure safety, the rated current loading of the socket should not be less than 10A; do not share the socket with other appliances; and the socket should be connected to circuit equipped with earth-leakage circuit breaker.
3. The socket should be properly grounded. To avoid hazards, the earth wire should not hook up with water pipes, gas pipes, lightning arresters and telephone lines.
4. Do not let the appliance sustain any weight pressure after installation; otherwise it could damage the interior parts.



# Installation Instructions

1. Follow the diagram below to make room in a cabinet to smoothly embed the sterilizer. Open the drawer and use four wood screws to fix the sterilizer.
2. The mounting height of dish sterilizer is discretionary, but the loading capacity of the supporting base should be greater than 60kg.
3. The dish sterilizer should lie firmly on a flat surface. Make sure the drawer does not judder when it runs on the slide rail. Fully close the drawer to form an airtight enclosure.

## Installation Diagram

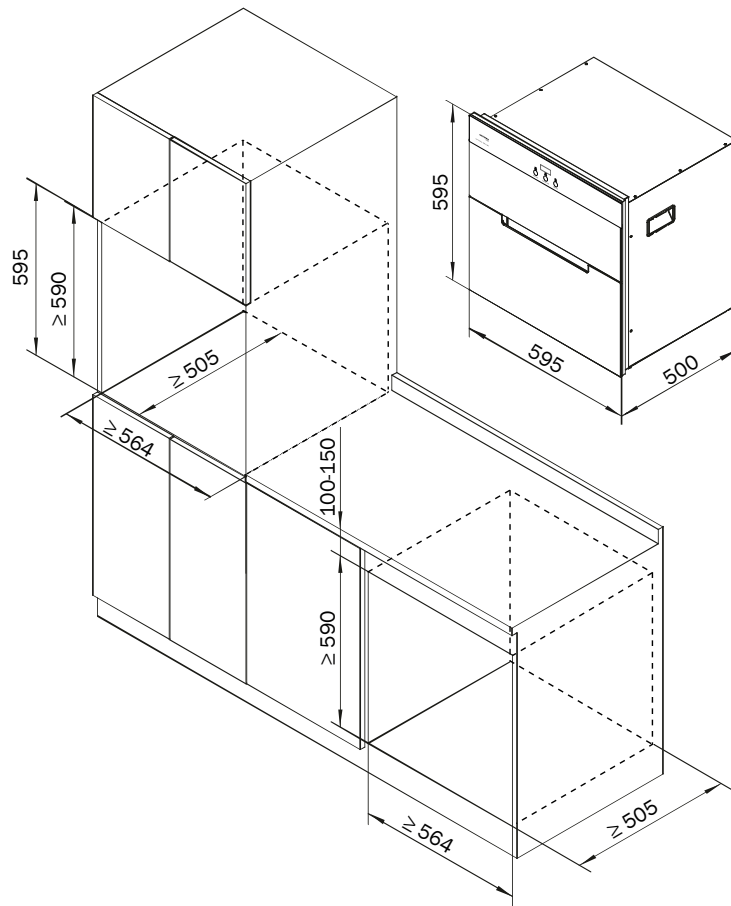

# Product Structure

## Main Body

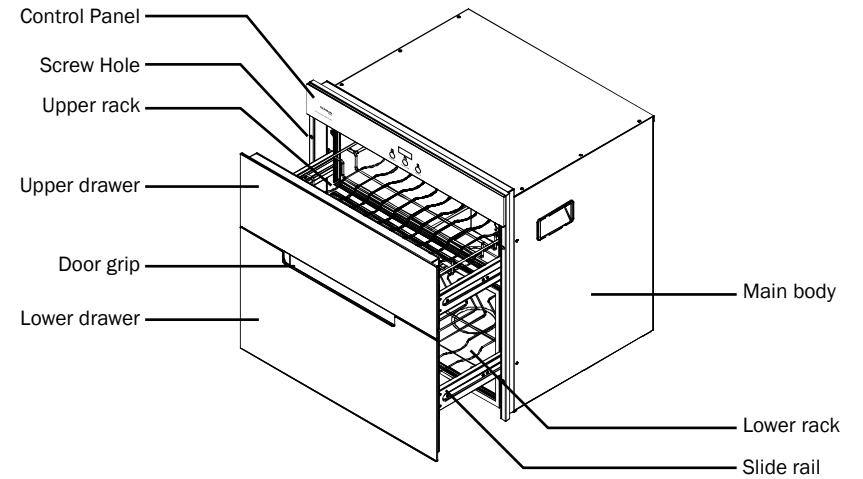

## Control panel

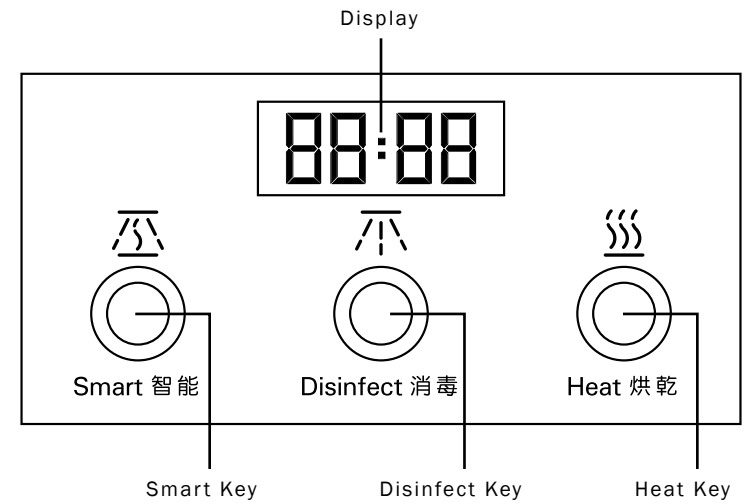

# Operating Instructions

## 1. Open/close the door

Hold the door grip to horizontally pull out or push in the door. Do not apply brute force.

## 2. Tableware arrangement

Vertically place the clean and dry tableware on the dish rack. The spacing between the dishes should be sufficiently wide, otherwise the disinfection and heat drying result will be affected.

## 3. Auto power off protection

Upon opening the drawer, the sterilizer enters inactive mode and all functionalities will be suspended. Only by closing the drawer will resume operation.

## 4. Function Key

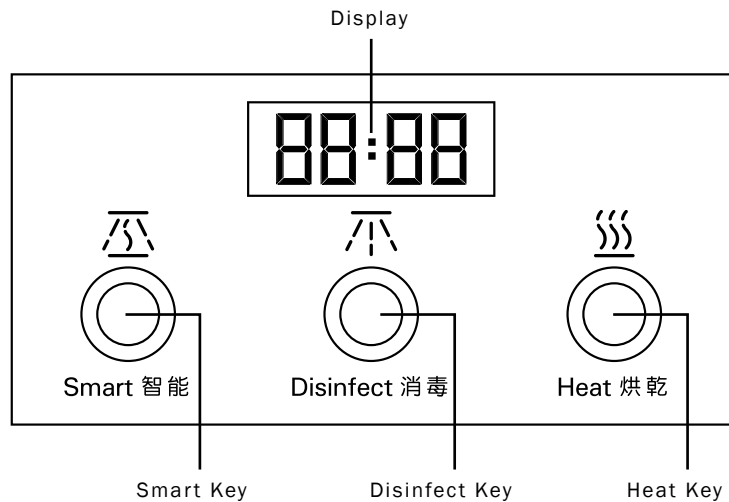

### System Initialization:

Make sure the appliance is properly installed in place. Close the drawer before connecting it to AC source. Plugging into the socket will emit a ticking sound, indicating the power is on and the machine enters standby mode.

# Operating Instructions

## Disinfection function:

On standby mode, press the "Disinfect" button. The corresponding indicator lights up and the timer reads 90:00. The disinfection duration can be set within 5 seconds. Press the button once again, the timer reads 60:00. Pressing 3 times the timer reads 30:00. The display turns off upon the 4th press. After setting the timer, if no other instructions are given within 5 seconds, the sterilizer will start running. When the timer ends at 00:00, disinfection is complete and 16 ticking sounds will be emitted.

## Heat-Dry function:

On standby mode, press the "Heat" button. The corresponding indicator lights up and the timer reads 90:00. The heat-dry duration can be set within 5 seconds. Press the button once again, the timer reads 60:00. Pressing 3 times the timer reads 30:00. The display turns off upon the 4th press. After setting the timer, if no other instructions are given within 5 seconds, the sterilizer will start running. When the timer ends at 00:00, heat-drying is complete and 16 ticking sounds will be emitted.

## Smart mode:

On standby mode, press the "Smart" button. The corresponding indicator lights up and the timer reads 60:00. If no other instructions are given within 5 seconds, the sterilizer will enter the Auto mode. When the timer ends at 00:00, the disinfection is complete. After a short while, the device will enter the standby mode with the timer starting to count from 45:00 to 00:00. Then the heat-dry function will be activated with the timer starting to count down from 60:00. When the timer ends at 00:00, heat-drying is complete and 16 ticking sounds will be emitted.

## Integrated functions:

On standby mode, press the "Disinfect" button to set the timer. Then quickly press the "Heat" button within 5 seconds to integrate the disinfection and heat-dry function. Reversing the sequence of pressing the 2 buttons will yield the same result. The timer can be set at either 90, 60 or 30 minutes.

When the sterilizer runs on the integrated mode, the disinfection function will precede the heat-dry function. When disinfection is complete, the sterilizer will enter standby mode for 45 minutes before proceeding to heat-dry operation. Disinfection and heat-drying cannot run simultaneously. The "disinfect" indicator and "heat" indicator cannot light up simultaneously as well. To attain optimal performance, a combination of 90-minute disinfection and 90-minute heat-drying is recommended.

## Safety Precautions

1. Hold the plug to unplug the sterilizer. Do not pull the cord to unplug the device.
2. If the power cord is damaged or other malfunctions occur, the appliance must be replaced or repaired by the manufacturer or qualified technicians.
3. Make sure the supply voltage is consistent with the rated voltage of the machine. Otherwise, damage to the appliance may result.
4. Except for qualified technicians, do not attempt to disassemble or repair the appliance.
5. Do not spray water onto the appliance, otherwise short circuit or electric shock may result.
6. Do not put lacquerware, thermally unstable plastic utensils or non-tableware (such as towels and shoes) into the dish sterilizer.
7. Water remained on the tableware should be discarded before putting it into the sterilizer.
8. To avoid scald or the leakage of ozone, the drawer should remain close for 20 minutes after disinfection (heat drying) completes.
9. To avoid scald, the appliance will automatically enter inactive mode when the drawer door is open. It is not a sign of malfunction.
10. When disinfection begins, the door will be locked. Do not tug the door.
11. Make sure the earth wire of the power socket is securely grounded.
12. Do not let children or physically unfit person operate the dish sterilizer, otherwise scald, electric shock or other accidents may result.
13. Do not plug or unplug the unit with a wet hand.
14. Do not place small objects outside the utensil basket to prevent them from dropping onto the lower rack.

### Warnings!

1. If leakage of ozone is detected or the light from germicidal tube can be seen through opaque objects at any angle during operation, stop using the appliance immediately and contact qualified technicians for repair.
2. If the germicidal tube is damaged, contact Repairs and Customer Service Center to replace it with a new one having 15W power and a wavelength of 253.7nm.
3. The disinfection and heat-dry function can only be performed when the door is close. Otherwise, leakage of ozone and UV radiation, or scald may result.

## Care and Maintenance

Clean and maintain the sterilizer regularly according to the frequency of usage and conditions of the surrounding environment so that optimal disinfection and heat drying performance can be maintained and a longer service life can be achieved.

- Turn off and unplug the appliance and allow it to cool down before cleaning and maintenance.
  - Wear gloves while performing cleaning and maintenance to avoid potential injuries.
1. Use a soft cloth dipped in neutral detergent to remove dirt on the door, dish rack and inner tank. Wipe clean the residual detergent with another wet cloth and finally rub them with a dry cloth.
  2. Regularly remove stagnant water accumulated at the bottom of the inner tank to avoid water overflow.
  3. Never clean the exterior with petrol, alcohol, cleaning powder or other solvents. Otherwise it can discolour the main body or damage the surface coating.

Watch the video clip



## Technical Specifications

Model	DSR-310BK
Rated voltage/Frequency	220 V / 50 Hz
Power (Max)	310W
Ozone concentration (mg/m <sup>3</sup> )	≥ 40
Capacity (L)	100
Net weight (kg)	26 kg
Loading capacity (kg)	Upper:6 Lower:8
Heat-drying temperature (°C)	≤ 75
Main Body Dimensions (mm)	(H)595mm X (W)595mm X (D)500mm
Installation Dimensions (mm)	(H) ≥ 590mm X (W) ≥ 564 X (D) ≥ 505mm

Specifications are subject to change without prior notice.

If there is any inconsistency or ambiguity between the English version and the Chinese version, the Chinese version shall prevail. Refer to [www.germanpool.com](http://www.germanpool.com) for the most up-to-date version of the Operating Instructions.

# Circuit Diagram

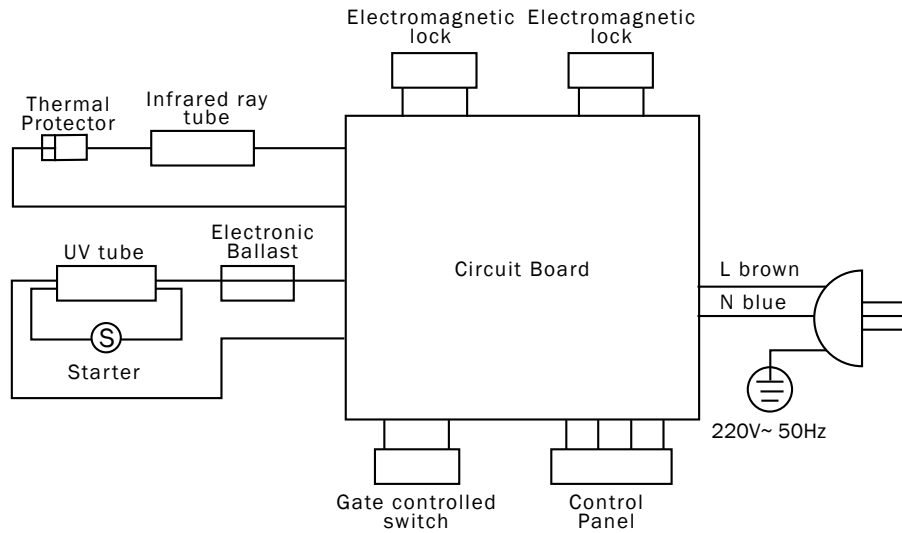

# 保用條款

此保用提供德國寶產品之機件在正常使用下壹年保用 (自購買日起計算)。

\* 貴戶須在購機十天內，以下列其中一種方式向本公司登記資料，保用手續方正式生效：

- 1) 填妥本公司網頁內之保用登記表格  
[www.germanpool.com/warranty](http://www.germanpool.com/warranty)
- 2) 填妥保用登記卡，郵寄至本公司。



# Warranty Terms & Conditions

Under normal operations, the product will guarantee a 1-year full warranty provided by German Pool (effective from the date of purchase).

\* This warranty is not valid until customer registration information is received by our Service Centre within 10 days of purchase via one of the following means:

- 1) Visit our website and register online:  
[www.germanpool.com/warranty](http://www.germanpool.com/warranty)
- 2) Complete all the fields on the attached Warranty Card and mail it back to our Customer Service Centre.



另請填妥以下表格並與正本發票一併保存，以便維修時核對資料。用戶提供之所有資料必須正確無誤，否則免費保用將會無效。Please fill out the form below. This information and the original purchase invoice will be required for any repairs. Warranty will be invalidated if information provided is found to be inaccurate.

型號 Model No. : **DSR-310BK**

機身號碼 Serial No. : \_\_\_\_\_ 發票號碼 Invoice No. : \_\_\_\_\_

購買商號 Purchased From : \_\_\_\_\_ 購買日期 Purchase Date : \_\_\_\_\_

1. 未能出示購買發票正本者，將不獲免費維修服務。
2. 用戶應依照說明書的指示操作。本保用並不包括：
  - 上門安裝、檢驗、維修或更換零件之人工以及一切運輸費用；
  - 因天然與人為意外造成的損壞 (包括運輸及其他)；
  - 電源接合不當、不依說明書而錯誤或疏忽使用本機所引致之損壞。
3. 於下列情況下，用戶之保用資格將被取消：
  - 購買發票有任何非認可之刪改；
  - 產品被用作商業或工業用途；
  - 產品經非認可之技術人員改裝或加裝任何配件；
  - 機身編號被擅自塗改、破壞或刪除。
4. 總代理有權選擇維修或更換配件或其損壞部份。
5. 產品一經被轉讓，其保用即被視作無效。

1. Customer who fails to present original purchase invoice will not be eligible for free warranty service.
2. Customer should always follow the operating instructions. This warranty does not apply to:
  - labour costs for on-site installation, check-up, repair, replacement of parts and other transportation costs;
  - damages caused by accidents of any kind (including material transfer and others);
  - operating failures resulting from applying incorrect voltage, improper usage, and unauthorized installations or repairs.
3. This warranty is invalid if:
  - the purchase invoice is modified by an unauthorized party;
  - the product is used for any commercial or industrial purposes;
  - the product is repaired or modified by unauthorized personnel, or unauthorized parts are installed;
  - the serial number is modified, damaged or removed from the product.
4. German Pool will, at its discretion, repair or replace any defective part.
5. This warranty will be void if there is any transfer of ownership from the original purchaser.

## 客戶服務及維修中心

中國香港

九龍灣啟興道1-3號

九龍貨倉10樓

電話：+852 2333 6249

傳真：+852 2356 9798

電郵：repairs@germanpool.com

中國澳門

澳門俾利喇街145號

寶豐工業大廈3樓

電話：+853 2875 2699

傳真：+853 2875 2661

## Customer Service & Repair Centre

Hong Kong, China

10/F, Kowloon Godown

1-3 Kai Hing Road, Kowloon Bay,

Kowloon, Hong Kong

Tel : +852 2333 6249

Fax : +852 2356 9798

Email : repairs@germanpool.com

Macau, China

3/F, Edificio Industrial Pou Fung,

145 Rua de Francisco Xavier Pereira,

Macau

Tel : +853 2875 2699

Fax : +853 2875 2661

GERMAN  
POOL



德國寶

## 德國寶(香港)有限公司 German Pool (Hong Kong) Limited

### 中國香港 Hong Kong, China

香港九龍土瓜灣馬頭角道116號  
新寶工商中心2期113號室  
Room 113, Newport Centre Phase II, 116 Ma Tau  
Kok Road, Tokwawan, Kowloon, Hong Kong.  
電話 Tel: +852 2773 2888  
傳真 Fax: +852 2765 8215

### 中國內地 Mainland China

廣東省佛山市順德區  
大良五沙工業區新翔路8號  
8th, Xinxiang Road, Wusha Industrial Park,  
Daliang, Shunde, Foshan, Guangdong, China  
電話 Tel: +86 757 2980 8308  
傳真 Fax: +86 757 2980 8318

### 中國澳門 Macau, China

澳門俾利喇街145號  
寶豐工業大廈3樓  
3/F, Edificio Industrial Pou Fung,  
145 Rua de Francisco Xavier Pereira, Macau  
電話 Tel: +853 2875 2699  
傳真 Fax: +853 2875 2661



香港名牌十年成就獎  
HONG KONG TOP BRAND TEN YEAR  
ACHIEVEMENT AWARD



香港(S-MARK)  
安全認證



中國名牌十年成就獎  
十大影響力品牌

CEO

CEO非凡品牌大賞



香港優質獎牌



香港工商業獎



最具器質  
創建品牌企業獎

商

香港中小企業  
最佳投資大獎



香港消費者推銷品牌



香港(O'牌)  
優質服務證書

© 版權所有。未獲德國寶授權，不得翻印、複製或使用本說明書作任何商業用途，違者必究。

© All rights reserved. Copying, reproducing or using the contents of this manual is not allowed without prior authorization from German Pool, violators will be prosecuted.

[www.germanpool.com](http://www.germanpool.com)