

# MULTIFUNCTIONAL MINI STEAMER

EGG-367



## USER MANUAL

Please read these instructions and warranty information carefully before use and keep them handy for future reference.

## Warnings and Safety Precautions

### **WARNING!**



Read all instructions carefully before using this product.

- This product is for domestic indoor use only. If this product is used for any commercial, industrial, rental or other purposes, product warranty will be VOIDED.
- This product is not intended for use by children or persons with reduced physical, sensory or mental capabilities, or lack of experience and knowledge, unless they have been given supervision or instruction concerning use of this product by an adult responsible for their safety.
- Mind your children and DO NOT let children play with this product.
- Cleaning and user maintenance shall not be made by children without supervision.
- Check the voltage indicated on the rating label before using this product.
- If the supply cord is damaged, it must be replaced by the manufacturer, its service agent or similarly qualified persons in order to avoid hazards.
- Unplug this product from the power source before cleaning and maintenance.
- Contact German Pool authorized service technician for repair or maintenance of this product.

### **WARNING!**

- Hot steam escapes from the steam outlet on the top of the lid during operation, DO NOT touch in order to avoid scalding. Use only the two side handles to open the lid.
  - Keep this product out of reach of children and infirm persons to avoid accidents.
1. Please read these instructions before operating and retain for future reference.
  2. This product can be used by children aged from 8 years and above if they have been given supervision or instruction concerning use of the appliance in a safe way and if they understand the hazards involved. Cleaning and user maintenance shall not be made by children unless they are older than 8 and supervised. Keep the appliance and its cord out of reach of children aged less than 8 years.
  3. Appliances can be used by persons with reduced physical, sensory or mental capabilities or lack of experience and knowledge if they have been given supervision or instruction concerning use of the appliance in a safe way and understand the hazards involved.

4. Children shall not play with this product.
5. If the supply cord is damaged, it must be replaced by German Pool Customer Service & Repair Centre in order to avoid a hazard.
6. CAUTION: Avoid injuries from the egg pricker.
7. Heating element surface is subject to residual heat after use.
8. Use this product according to this user manual, any misuse may cause electric shock or other hazards.
9. This appliance is intended to be used in household and similar applications such as: staff kitchen areas in shops, offices and other working environments; farm houses; by clients in hotels, motels and other residential type environments; bed and breakfast type environments.
10. To protect against electrical hazard, DO NOT immerse any part of this product or cord in water or any other liquid.
11. Regarding how to clean the surfaces in contact food, please refer to the "Cleaning & Maintenance" section.
12. Always use this product on a dry, clean, stable and level surface.
13. Only use this product for its intended purpose and indoors.
14. Always unplug from the plug socket when not in use and before cleaning.
15. Never start up this product without filling water into the cooking tray.
16. DO NOT operate this product if damaged, after this product has malfunctioned or been damaged in any manner. Return to German Pool Customer Service & Repair Centre for repair, because special purpose tools are required
17. DO NOT let the cord hang over the edge of a table or counter or touch hot surfaces. Allow this product to cool before wrapping cord around base for storage.
18. DO NOT move this product and DO NOT pull at the cord during operation.
19. DO NOT move this product while it still has hot water in it.
20. Care must be taken not to touch any hot surfaces. DO NOT store or cover this product until it has fully cooled down.
21. DO NOT place this product on or near a hot gas or electric burner, in or where it could touch a heated oven, or a microwave oven.
22. DO NOT use harsh abrasives, caustic cleaners or oven cleaners when cleaning this product.
23. Let this product cool down in a safe place, inaccessible to children, before you clean it.
24. This product is not designed for commercial purposes.

25.  **WARNING! Danger of swallow:** Lay the egg pricker protector in a safe place, do not allow children to play with it.
26.  **WARNING! Danger of electric shock:** Never attempt to repair this product yourself. In case of defects only let qualified specialists from German Pool Customer Service & Repair Centre repair this product.
27.  **WARNING! Danger of burns:** this product will become very hot during operation. DO NOT remove the top cover until the buzzer sets in. Regarding the operational details, refer to the section of “Operating Instructions”.

#### Correct Disposal of this Product



This marking indicates that this product should not be disposed with other household wastes. To prevent possible harm to the environment or human health from uncontrolled waste disposal, recycle it responsibly to promote the sustainable reuse of material resources. To return your used device, please use the return  and collection systems. They can take this product for environmental safe recycling.

## Product Structure

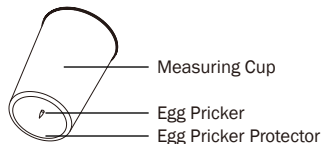
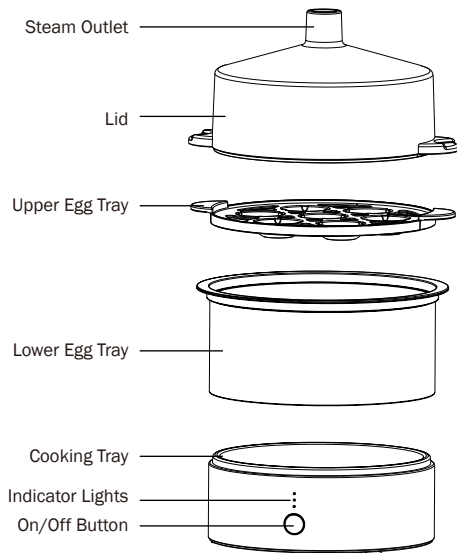

## Operation Instructions

### Note:

This product must be placed on a flat and level surface during use, otherwise it may stop heating prematurely and result in undercooked eggs.

1. Unwind the cable up to the desired length, plug into the power outlet. The product's indicator lights go dark, and product enters standby state.
2. Measure the required amount of water with the supplied measuring cup. Fill clear cold water up to the respective mark on the measuring cup and then pour into the cooking tray. DO NOT fill to above the maximum water mark.
3. Before placing the egg into the egg tray, pierce the blunt end of the egg with the egg pricker located on the bottom of the measuring cup. This prevents the egg from cracking. Then place the egg blunt side up into the egg tray, or place in other food ingredients, and put on the lid.

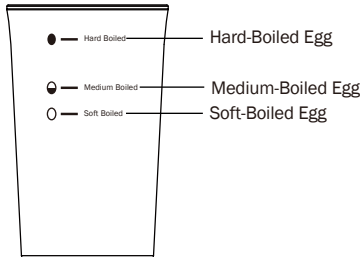

### Note:

- This product can be used as a single-layer or double-layer steamer. For single-layer use, place the upper egg tray directly onto the main unit. For double-layer use, first place the lower egg tray onto the main unit, then stack the upper tray on top.
  - When using the upper egg tray to cook foods other than eggs, user must first place the stainless steel steam rack inside the tray before adding the food.
4. Press On/Off Button repeatedly to cycle among desired modes: Single Layer Soft-Boiled Egg > Single Layer Medium-Boiled Egg > Single Layer Hard-Boiled Egg > Double Layer Steaming (Hard-Boiled Egg) > Standby, corresponding indicator lights light up constant, product issues a voice prompt and starts cooking.

Indicator Light	Function/Mode	Description
○ ○ ○	Standby	Power is connected but no mode is selected; indicator lights go dark, and product enters Standby state
○ ○ ●	Single Layer Soft-Boiled Egg	Press On/Off Button once, the bottom indicator light lights up constant, product enters Single Layer Soft-Boiled Egg Mode. Use Upper Egg Tray for this mode (max. 7 eggs)
○ ● ○	Single Layer Medium-Boiled Egg	Press On/Off Button twice, the middle indicator light lights up constant, product enters Single Layer Medium-Boiled Egg Mode. Use Upper Egg Tray for this mode (max. 7 eggs)
● ○ ○	Single Layer Hard-Boiled Egg	Press On/Off Button 3 times, the upper indicator light lights up constant, product enters Single Layer Hard-Boiled Egg Mode. Use Upper Egg Tray for this mode (max. 7 eggs)
● ● ●	Double Layer Steaming (Hard-Boiled Egg)	Press On/Off Button 4 times, all three indicator lights light up constant, product enters Double Layer Steaming (Hard-Boiled Egg) Mode. Use both Upper Egg Tray and Lower Egg Tray for this mode. Suitable for steaming hard-boiled eggs, or foods like sweet potatoes, Chinese yam, corn, carrot, spare rib, potato, Chinese bun, etc.

#### Note:

- When opening the lid, be cautious of hot steam escaping. Hold the lid by its handles and tilt the lid slightly to allow condensed water to drip back into the cooking tray.
  - As desired level of doneness varies by personal preference, actual results may differ slightly from the standard mode settings. User can adjust the amount of water according to preference, but DO NOT allow the water level to exceed the maximum water mark inside the cooking tray.
5. When cooking is done, the product will automatically return to standby state, indicator lights will go dark, and product will issue a voice prompt. Hold the lid and trays by their handles, place on to a level and heat-resistant surface, take out the eggs and put into ice water to prevent from further heating.



## Dry Boil Protection

If the water in the cooking tray falls too low during operation, the product will automatically activate the dry boil protection mechanism. The cooking tray will stop heating, and all indicator lights will blink. Immediately unplug the power cord, add water, and then restart the product.

## Adjusting Voice Prompt Volume

This product provides voice prompts during operation. To adjust the volume, follow the steps below:

In standby state, press and hold On/Off Button for 5 seconds to enter Volume Adjustment Mode. Within 3 seconds, press the On/Off Button repeatedly to cycle through the volume levels, and the corresponding indicator light will remain on. After adjustment, if no operation is performed within 5 seconds, the appliance will automatically confirm the selected volume level and return to standby state.

Voice Prompt Off	Low Volume	High Volume
		

## Cleaning & Maintenance

### **WARNING!**

- Turn off the power, disconnect product from the power source and let the product cool down completely before cleaning and maintenance.
  - DO NOT immerse the product body in water or any liquid.
1. It is normal to have residual water left inside the cooking tray after cooking. Allow product to completely cool down, pour off the residual water, and wipe the cooking tray clean with a moist cloth. In case of scale deposits, pour a little diluted vinegar into the cooking tray, let it sit for approx. 30 minutes, then carefully rinse out with water. Take care not to wet the outside of the product. DO NOT use detergent or cleansing agents.
  2. The heating plate is made of stainless steel. What may appear as rust stain is usually just stubborn residue, please wipe with special cleansing agent for stainless steel, please wipe with special cleansing agent for stainless steel.
  3. It is recommended to use a moist cloth to wipe the exterior of the main unit, then wipe dry with a soft dry cloth. DO NOT immerse the product body in water.

## Technical Specification

<b>Model</b>	<b>EGG-367</b>
Voltage / Frequency	220-240 V~ 50/60 Hz
Power	410 W
Max. no of Eggs per time	14
Product Dimensions	(H) 240 (W) 201 (D)164.5 mm
Net Weight	0.8 kg

- Specification is subject to change without prior notice.
- If there is any inconsistency or ambiguity between the English version and the Chinese version, the English version shall prevail.
- Refer to [www.germanpool.com](http://www.germanpool.com) for the most update version of the user manual.

EGG-367-M-26(1)

## 保用條款 Warranty Terms & Conditions

此保用提供德國寶產品之機件在正常使用下壹年保用（自購買日起計算）。貴戶須在購機十天內，以下列其中一種方式登記資料，保用手續方正式生效：

Under normal operations, the product will gurantee a 1-year full warranty provided by German Pool (effective from the date of purchase). This warranty is not valid until customer registration information is received by our Service Centre within 10 days of purchase via one of the following means:



- 1) 填妥德國寶VIP手機應用程式保用登記表（掃描左方二維碼）
- 2) 填妥本公司網頁保用登記表 <http://www.germanpool.com/warranty>
- 1) Visit our VIP App and register online: (Scan the QR Code on the left)
- 2) Visit our website and register online: <http://www.germanpool.com/warranty>

另請填妥以下表格並與正本發票一併保存，以便維修時核對資料。用戶提供之所有資料必須正確無誤，否則免費保用將會無效。

Please fill out the form below. This information and the original purchase invoice will be required for any repairs. Warranty will be invalidated if information provided is found to be inaccurate.

型號 Model No.: EGG-367

機身號碼 Serial No.: \_\_\_\_\_

發票號碼 Invoice No.: \_\_\_\_\_

購買商號 Purchased From: \_\_\_\_\_

購買日期 Purchased Date: \_\_\_\_\_

## 警告及注意事項



### 警告！

- 使用本產品前，請仔細閱讀所有說明。
- 本產品只限家居室內日常使用，如產品作任何商業、工業、出租或其他用途，保用證即告失效。
- 嚴禁讓兒童或身體有殘障、精神不健全及對本產品缺乏經驗或知識人士單獨使用本產品；如需使用，必須要在負責任的成年人監管下方可使用。
- 應照顧好兒童，確保他們不會玩耍本產品。
- 無成年人監管下，勿讓兒童清潔及維護本產品。
- 使用前，請先檢查所有電壓是否與本產品標籤上的電壓相符。
- 如果電源線損壞，為免發生意外，電源線必須由廠方、廠方指定的維修中心或同等合格的技術人員進行更換。
- 清潔或檢查本產品前，必須先關機及拔掉插頭。
- 請聯繫德國寶授權的技術人員進行維修或保養本產品。

### 警告！

- 本產品鍋蓋突出位置為蒸氣出口，使用期間會釋放高溫蒸氣，嚴禁觸碰以免燙傷。如需打開鍋蓋，必須使用兩側的手柄。
- 本產品必須放置於遠離兒童或體弱人士，且他們無法觸及的地方，以免發生危險。

1. 使用本產品前，必須先閱讀本說明書，並妥善保存以作日後參考。
2. 本產品可供8歲或以上兒童使用，但必須在安全使用指導或監督下進行，並確保其了解相關危險。清潔及保養不得由兒童進行，除非其年滿8歲並在監督下操作。請將本產品及其電源線放置於8歲以下兒童無法觸及的地方。
3. 本產品不適合身體、感官或精神能力較弱，或缺乏使用經驗及知識的人士（包括兒童）使用，除非有負責其安全的人士對其進行監督或指導。
4. 必須看管兒童，確保他們不會把本產品當作玩具。
5. 若電源線損壞，必須由德國寶客戶服務及維修中心更換，以避免危險。
6. 注意：使用量杯底部的刺蛋針時，必須小心避免受傷。
7. 加熱元件表面在使用後仍會有餘熱，小心燙傷。
8. 必須按照本說明書使用本產品，任何不當使用都可能導致觸電或其他危險。
9. 本產品適用於家用及類似用途，例如：商店、辦公室及其他工作場所的員工茶水間；農舍；酒店、汽車旅館及其他住宿環境供客人使用；民宿類型環境。
10. 為避免觸電危險，嚴禁將產品任何部分或電源線浸入水或其他液體中。
11. 有關清潔與食物接觸表面的說明，請參閱「清潔及保養」章節。
12. 使用時必須將本產品放置於乾燥、清潔、穩固及平坦的表面。
13. 本產品只供室內使用，並僅限於其設計用途。
14. 不使用或清潔本產品前，必須拔除電源插頭。
15. 如未在加熱底座中加入水，嚴禁啟動本產品。
16. 如本產品損壞、出現故障或以任何方式受損，必須停止使用並聯絡德國寶客戶服務及維修中心，因維修需使用專用工具。
17. 嚴禁讓電源線懸掛於桌邊或檯面邊緣，或接觸高溫表面。收納前必須待產品完全冷卻，再將電源線繞於底座。

18. 使用期間嚴禁移動本產品，嚴禁拉扯電源線。
19. 當本產品內仍有熱水時，嚴禁移動。
20. 必須避免接觸任何高溫表面；在產品完全冷卻前，嚴禁收納或覆蓋。
21. 嚴禁將本產品放置於或靠近燃氣爐、電爐、已加熱的焗爐或微波爐附近。
22. 清潔本產品時嚴禁使用強力磨蝕性清潔劑、腐蝕性清潔劑或焗爐清潔劑。
23. 清潔本產品前必須將產品放在兒童無法觸及的安全地方並待其徹底冷卻。
24. 本產品並非為商業用途而設計。
25.  **警告！誤吞危險：**必須將刺蛋針保護蓋妥善放置於安全位置，嚴禁讓兒童玩耍。
26.  **警告！觸電危險：**嚴禁自行維修本產品。如有故障，必須聯絡德國寶客戶服務及維修中心，由合資格的專業人員進行維修。
27.  **警告！燙傷危險：**本產品在運作期間會變得非常高溫。在語音提示響起前，嚴禁打開鍋蓋。

### 本產品的正確處理方式



此標誌表示本產品不得與其他家庭廢棄物一同棄置。為避免因不當處理廢棄物而對環境或人體健康造成危害，請以負責任的方式回收本產品，以促進資源的可持續再利用。如需棄置已使用的設備，請使用相關回收及收集系統，他們可協助將本產品進行環保回收處理。

## 產品結構

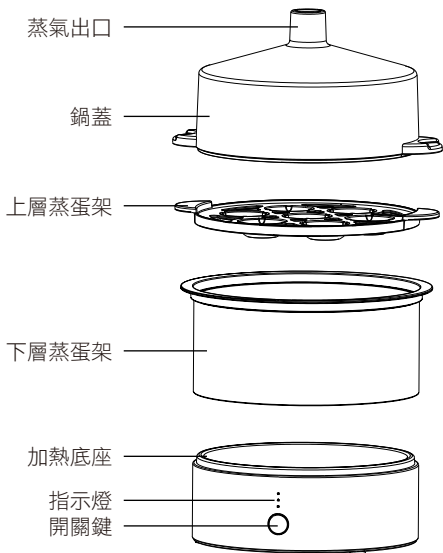

## 使用說明

### 注意：

使用時必須將本產品放置於水平位置，否則可能過早停止加熱，導致雞蛋過於軟熟。

1. 將電源線拉出至所需長度，插入電源插座，產品指示燈熄滅，進入待機狀態。
2. 使用跟機隨送的量杯，按相應刻度量取所需水量後往加熱底座加入清水，注意水量嚴禁超過最高水位線（MAX標記）。
3. 將蛋架穩妥地安裝在主機上，放入雞蛋前，使用量杯底部的刺蛋針在雞蛋鈍端刺一小孔以防止雞蛋在加熱時爆裂；然後雞蛋鈍端朝上放入雞蛋槽，蓋上鍋蓋。

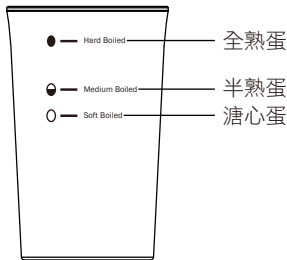

### 注意：

- 本產品可單層或雙層使用，單層使用時，直接將上層蒸蛋架安裝在主機上；雙層使用時，先將下層蒸蛋架安裝在主機上，再安裝上層蒸蛋架。
  - 如需使用上層蒸蛋架蒸煮除雞蛋以外其他食材，必須先放上不銹鋼蒸架，再放置食材。
4. 重複按「開關鍵」循環選擇所需模式：單層溏心蛋 > 單層半熟蛋 > 單層全熟蛋 > 雙層蒸煮（全熟蛋） > 待機，對應指示燈常亮，產品發出語音提示後開始烹調。

指示燈	功能/模式	說明
○ ○ ○	待機	接通電源後未有選擇任何模式，指示燈熄滅，產品處於待機狀態
○ ○ ●	單層溏心蛋	按「開關鍵」1次，底端指示燈常亮進入單層溏心蛋模式，適用於使用上層蒸蛋架烹調溏心蛋（最多7個雞蛋）
○ ● ○	單層半熟蛋	按「開關鍵」2次，中間指示燈常亮進入單層半熟蛋模式，適用於使用上層蒸蛋架烹調半熟蛋（最多7個雞蛋）
● ○ ○	單層全熟蛋	按「開關鍵」3次，頂端指示燈常亮進入單層全熟蛋模式，適用於使用上層蒸蛋架烹調全熟蛋（最多7個雞蛋）
● ● ●	雙層蒸煮 (全熟蛋)	按「開關鍵」4次，所有指示燈常亮進入雙層蒸煮（全熟蛋）模式，適用於上下層蒸蛋架同時使用烹調全熟蛋、番薯、淮山、粟米、紅蘿蔔、排骨、薯仔及饅頭等食物

#### 注意：

- 打開鍋蓋時必須小心高溫蒸氣溢出，必須握住手柄位置稍微傾斜鍋蓋，讓冷凝水滴落。
- 由於雞蛋熟度因個人口味而異，實際效果可能與模式標準略有不同，您可按個人喜好調整水量，但加水時嚴禁超過加熱底座上的最高水位線。

5. 烹調完成後，產品會自動返回待機狀態，指示燈熄滅並發出語音提示。使用兩側把手取出打開鍋蓋及取出蛋架放在平坦表面，取出雞蛋並放入冷水中冷卻，避免過度熟成。

## 防乾燒功能

在加熱過程中如加熱底座的水用盡或水量過低，產品會自動進入防乾燒功能，發熱盤停止加熱，所有指示燈同時閃爍。請即拔除電源線，待加水後再重新開機使用。

## 調校語音提示聲量

本產品在使用過程中會發出語音提示，可按以下步驟調校聲量：

在待機模式下，長按「開關鍵」5秒，進入聲量調節模式，3秒內重複按「開關鍵」循環調節聲量檔位，相應指示燈常亮。調校完成後，如5秒內無任何操作，產品將自動確認所選聲量檔位，並返回待機狀態。

語音提示關閉	低檔聲量	高檔聲量
		

## 清潔及保養

### ⚠ 警告！

- 清潔及保養前必須關閉電源，拔掉插頭，並讓產品完全冷卻。
  - 嚴禁將本產品浸入水或任何液體中。
1. 使用後加熱底座內仍有少量殘留水屬正常現象，待產品冷卻後，倒掉剩餘的水並用濕布清潔加熱板。如有水垢沉積，可使用稀釋醋浸泡約30分鐘，再徹底沖洗，小心不可弄濕外殼。嚴禁使用磨蝕性清潔劑。
  2. 加熱底座採用不銹鋼製成。若出現鐵銹痕跡，通常只是附著在表面的殘留物，可使用不銹鋼專用清潔劑去除。
  3. 建議用微濕的布擦拭本產品外殼，然後用柔軟乾布擦乾，嚴禁將本產品浸入水中。

## 技術規格

型號	EGG-367
電壓 / 頻率	220-240 V~ 50/60 Hz
功率	410 W
雞蛋容量	14
產品尺寸	(H) 240 (W) 201 (D)164.5 mm
淨重	0.8 kg

產品規格及設計如有變更，恕不另行通知。

中英文版本如有出入，一概以英文版為準。

本產品使用說明書以 [www.germanpool.com](http://www.germanpool.com) 網上版為最新版本。

EGG-367-M-26(1)

# GERMAN POOL

## MULTIFUNCTIONAL MINI STEAMER

EGG-367



## USER MANUAL

Please read these instructions and warranty information carefully before use and keep them handy for future reference.

### Warnings and Safety Precautions

#### ⚠ WARNING!

Read all instructions carefully before using this product.

- This product is for domestic indoor use only. If this product is used for any commercial, industrial, rental or other purposes, product warranty will be VOIDED.
- This product is not intended for use by children or persons with reduced physical, sensory or mental capabilities, or lack of experience and knowledge, unless they have been given supervision or instruction concerning use of this product by an adult responsible for their safety.
- Mind your children and DO NOT let children play with this product.
- Cleaning and user maintenance shall not be made by children without supervision.
- Check the voltage indicated on the rating label before using this product.
- If the supply cord is damaged, it must be replaced by the manufacturer, its service agent or similarly qualified persons in order to avoid hazards.
- Unplug this product from the power source before cleaning and maintenance.
- Contact German Pool authorized service technician for repair or maintenance of this product.

#### ⚠ WARNING!

- Hot steam escapes from the steam outlet on the top of the lid during operation, DO NOT touch in order to avoid scalding. Use only the two side handles to open the lid.
- Keep this product out of reach of children and infirm persons to avoid accidents.

- Please read these instructions before operating and retain for future reference.
- This product can be used by children aged from 8 years and above if they have been given supervision or instruction concerning use of the appliance in a safe way and if they understand the hazards involved. Cleaning and user maintenance shall not be made by children unless they are older than 8 and supervised. Keep the appliance and its cord out of reach of children aged less than 8 years.
- Appliances can be used by persons with reduced physical, sensory or mental capabilities or lack of experience and knowledge if they have been given supervision or instruction concerning use of the appliance in a safe way and understand the hazards involved.

- Children shall not play with this product.
- If the supply cord is damaged, it must be replaced by German Pool Customer Service & Repair Centre in order to avoid a hazard.
- CAUTION: Avoid injuries from the egg pricker.
- Heating element surface is subject to residual heat after use.
- Use this product according to this user manual, any misuse may cause electric shock or other hazards.
- This appliance is intended to be used in household and similar applications such as: staff kitchen areas in shops, offices and other working environments; farm houses; by clients in hotels, motels and other residential type environments; bed and breakfast type environments.
- To protect against electrical hazard, DO NOT immerse any part of this product or cord in water or any other liquid.
- Regarding how to clean the surfaces in contact food, please refer to the "Cleaning & Maintenance" section.
- Always use this product on a dry, clean, stable and level surface.
- Only use this product for its intended purpose and indoors.
- Always unplug from the plug socket when not in use and before cleaning.
- Never start up this product without filling water into the cooking tray.
- DO NOT operate this product if damaged, after this product has malfunctioned or been damaged in any manner. Return to German Pool Customer Service & Repair Centre for repair, because special purpose tools are required.
- DO NOT let the cord hang over the edge of a table or counter or touch hot surfaces. Allow this product to cool before wrapping cord around base for storage.
- DO NOT move this product and DO NOT pull at the cord during operation.
- DO NOT move this product while it still has hot water in it.
- Care must be taken not to touch any hot surfaces. DO NOT store or cover this product until it has fully cooled down.
- DO NOT place this product on or near a hot gas or electric burner, in or where it could touch a heated oven, or a microwave oven.
- DO NOT use harsh abrasives, caustic cleaners or oven cleaners when cleaning this product.
- Let this product cool down in a safe place, inaccessible to children, before you clean it.
- This product is not designed for commercial purposes.

- ⚠ WARNING! Danger of swallow: Lay the egg pricker protector in a safe place, do not allow children to play with it.
- ⚠ WARNING! Danger of electric shock: Never attempt to repair this product yourself. In case of defects only let qualified specialists from German Pool Customer Service & Repair Centre repair this product.
- ⚠ WARNING! Danger of burns: this product will become very hot during operation. DO NOT remove the top cover until the buzzer sets in. Regarding the operational details, refer to the section of "Operating Instructions".

#### Correct Disposal of This Product

This marking indicates that this product should not be disposed with other household wastes. To prevent possible harm to the environment or human health from uncontrolled waste disposal, recycle it responsibly to promote the sustainable reuse of material resources. To return your used device, please use the return and collection systems. They can take this product for environmental safe recycling.

### Product Structure

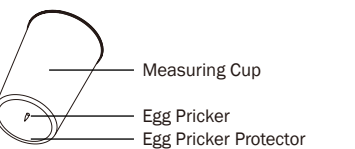
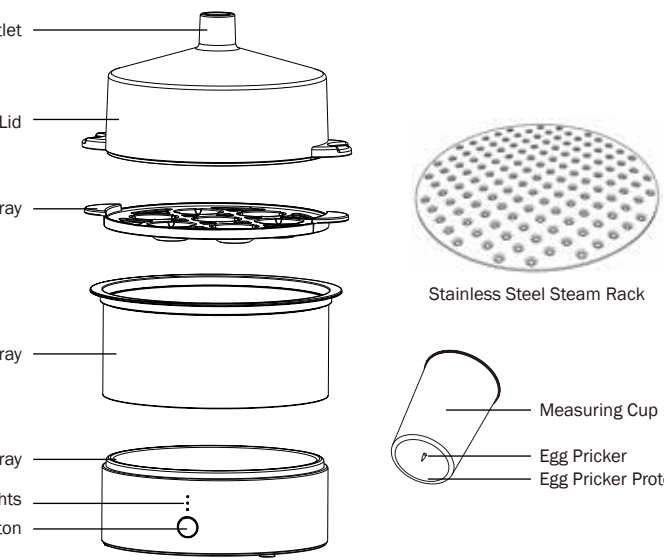

### 產品結構

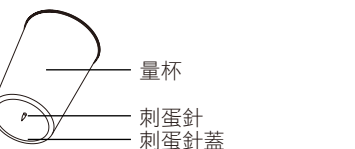
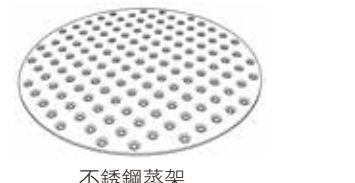
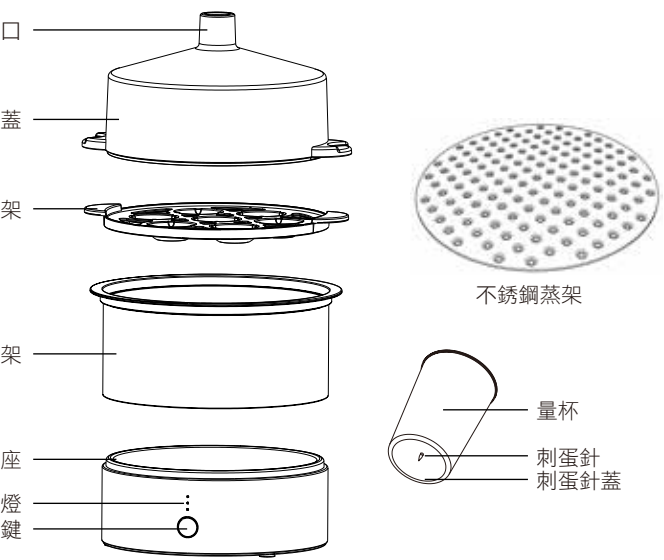

### 使用說明

#### 注意:

使用時必須將本產品放置於水平位置，否則可能過早停止加熱，導致雞蛋過於軟熟。

- 將電源線拉出至所需長度，插入電源插座，產品指示燈熄滅，進入待機狀態。
- 使用跟機贈送的量杯，按相應刻度量取所需水量後往加熱底座加入清水，注意水量嚴禁超過最高水位線 (MAX標記)。
- 將蛋架穩妥地安裝在主機上，放入雞蛋前，使用量杯底部的刺蛋針在雞蛋鈍端刺一小孔以防止雞蛋在加熱時爆裂；然後雞蛋鈍端朝上放入雞蛋槽，蓋上鍋蓋。

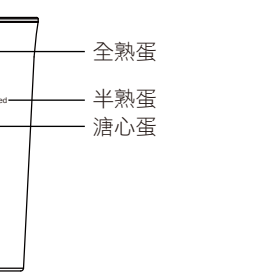

#### 注意:

- 本產品可單層或雙層使用，單層使用時，直接將上層蒸蛋架安裝在主機上；雙層使用時，先將下層蒸蛋架安裝在主機上，再安裝上層蒸蛋架。
- 如需使用上層蒸蛋架蒸煮除雞蛋以外其他食材，必須先放上不銹鋼蒸架，再放置食材。

- 重複按「開關鍵」循環選擇所需模式：單層溏心蛋 > 單層半熟蛋 > 單層全熟蛋 > 雙層蒸煮 (全熟蛋) > 待機，對應指示燈常亮，產品發出語音提示後開始烹調。

### Operation Instructions

#### Note:

This product must be placed on a flat and level surface during use, otherwise it may stop heating prematurely and result in undercooked eggs.

- Unwind the cable up to the desired length, plug into the power outlet. The product's indicator lights go dark, and product enters standby state.
- Measure the required amount of water with the supplied measuring cup. Fill clear cold water up to the respective mark on the measuring cup and then pour into the cooking tray. DO NOT fill to above the maximum water mark.
- Before placing the egg into the egg tray, pierce the blunt end of the egg with the egg pricker located on the bottom of the measuring cup. This prevents the egg from cracking. Then place the egg blunt side up into the egg tray, or place in other food ingredients, and put on the lid.

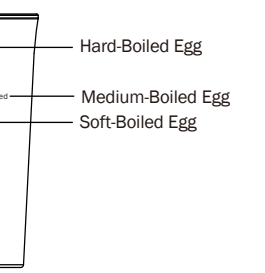

#### Note:

- This product can be used as a single-layer or double-layer steamer. For single-layer use, place the upper egg tray directly onto the main unit. For double-layer use, first place the lower egg tray onto the main unit, then stack the upper tray on top.
- When using the upper egg tray to cook foods other than eggs, user must first place the stainless steel steam rack inside the tray before adding the food.
- Press On/Off Button repeatedly to cycle among desired modes: Single Layer Soft-Boiled Egg > Single Layer Medium-Boiled Egg > Single Layer Hard-Boiled Egg > Double Layer Steaming (Hard-Boiled Egg) > Standby, corresponding indicator lights light up constant, product issues a voice prompt and starts cooking.
- When cooking is done, the product will automatically return to standby state, indicator lights will go dark, and product will issue a voice prompt. Hold the lid and trays by their handles, place on to a level and heat-resistant surface, take out the eggs and put into ice water to prevent from further heating.

### 使用說明

#### 注意:

使用時必須將本產品放置於水平位置，否則可能過早停止加熱，導致雞蛋過於軟熟。

- 將電源線拉出至所需長度，插入電源插座，產品指示燈熄滅，進入待機狀態。
- 使用跟機贈送的量杯，按相應刻度量取所需水量後往加熱底座加入清水，注意水量嚴禁超過最高水位線 (MAX標記)。
- 將蛋架穩妥地安裝在主機上，放入雞蛋前，使用量杯底部的刺蛋針在雞蛋鈍端刺一小孔以防止雞蛋在加熱時爆裂；然後雞蛋鈍端朝上放入雞蛋槽，蓋上鍋蓋。

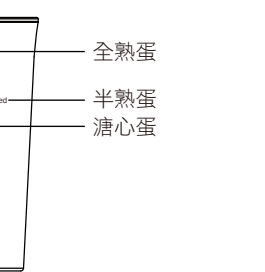

#### 注意:

- 本產品可單層或雙層使用，單層使用時，直接將上層蒸蛋架安裝在主機上；雙層使用時，先將下層蒸蛋架安裝在主機上，再安裝上層蒸蛋架。
- 如需使用上層蒸蛋架蒸煮除雞蛋以外其他食材，必須先放上不銹鋼蒸架，再放置食材。

- 重複按「開關鍵」循環選擇所需模式：單層溏心蛋 > 單層半熟蛋 > 單層全熟蛋 > 雙層蒸煮 (全熟蛋) > 待機，對應指示燈常亮，產品發出語音提示後開始烹調。

- 烹調完成後，產品會自動返回待機狀態，指示燈熄滅並發出語音提示。使用兩側把手取出打開鍋蓋及取出蛋架放在平坦表面，取出雞蛋並放入冷水中冷卻，避免過度煮熟。

### Technical Specification

Model	EGG-367
Voltage / Frequency	220-240 V~ 50/60 Hz
Power	410 W
Max. no of Eggs per time	14
Product Dimensions	(H) 240 (W) 201 (D)164.5 mm
Net Weight	0.8 kg

Specification is subject to change without prior notice.  
If there is any inconsistency or ambiguity between the English version and the Chinese version, the English version shall prevail.  
Refer to [www.germanpool.com](http://www.germanpool.com) for the most update version of the user manual.

### Dry Boil Protection

If the water in the cooking tray falls too low during operation, the product will automatically activate the dry boil protection mechanism. The cooking tray will stop heating, and all indicator lights will blink. Immediately unplug the power cord, add water, and then restart the product.

### Adjusting Voice Prompt Volume

This product provides voice prompts during operation. To adjust the volume, follow the steps below: In standby state, press and hold On/Off Button for 5 seconds to enter Volume Adjustment Mode. Within 3 seconds, press the On/Off Button repeatedly to cycle through the volume levels, and the corresponding indicator light will remain on. After adjustment, if no operation is performed within 5 seconds, the appliance will automatically confirm the selected volume level and return to standby state.

Voice Prompt Off	Low Volume	High Volume
○ ○ ○	○ ●	● ● ●

Model	EGG-367
Voltage / Frequency	220-240 V~ 50/60 Hz
Power	410 W
Max. no of Eggs per time	14
Product Dimensions	(H) 240 (W) 201 (D)164.5 mm
Net Weight	0.8 kg

Specification is subject to change without prior notice.  
If there is any inconsistency or ambiguity between the English version and the Chinese version, the English version shall prevail.  
Refer to [www.germanpool.com](http://www.germanpool.com) for the most update version of the user manual.

### Cleaning & Maintenance

#### ⚠ WARNING!

- Turn off the power, disconnect product from the power source and let the product cool down completely before cleaning and maintenance.
- DO NOT immerse the product body in water or any liquid.

- It is normal to have residual water left inside the cooking tray after cooking. Allow product to completely cool down, pour off the residual water, and wipe the cooking tray clean with a moist cloth. In case of scale deposits, pour a little diluted vinegar into the cooking tray, let it sit for approx. 30 minutes, then carefully rinse out with water. Take care not to wet the outside of the product. DO NOT use detergent or cleansing agents.
- The heating plate is made of stainless steel. What may appear as rust stain is usually just stubborn residue please wipe with special cleansing agent for stainless steel, please wipe with special cleansing agent for stainless steel.
- It is recommended to use a moist cloth to wipe the exterior of the main unit, then wipe dry with a soft dry cloth. DO NOT immerse the product body in water.

### Technical Specification

Model	EGG-367
Voltage / Frequency	220-240 V~ 50/60 Hz
Power	410 W
Max. no of Eggs per time	14
Product Dimensions	(H) 240 (W) 201 (D)164.5 mm
Net Weight	0.8 kg

Specification is subject to change without prior notice.  
If there is any inconsistency or ambiguity between the English version and the Chinese version, the English version shall prevail.  
Refer to [www.germanpool.com](http://www.germanpool.com) for the most update version of the user manual.

### 清潔及保養

#### ⚠ 警告!

- 清潔及保養前必須關閉電源，拔掉插頭，並讓產品完全冷卻。
- 嚴禁將本產品浸入水或任何液體中。

- 使用後加熱底座內仍有少量殘留水屬正常現象，待產品冷卻後，倒掉剩餘的水並用濕布清潔加熱板。如有水垢沉積，可使用稀釋醋浸泡約30分鐘，再徹底沖洗，小心不可弄濕外殼。嚴禁使用磨蝕性清潔劑。
- 加熱底座採用不銹鋼製成。若出現鐵銹斑跡，通常只是附著在表面的殘留物，可使用不銹鋼專用清潔劑去除。
- 建議用微濕的布擦拭本產品外殼，然後用柔軟乾布擦乾，嚴禁將本產品浸入水中。

### 技術規格

型號	EGG-367
電壓 / 頻率	220-240 V~ 50/60 Hz
功率	410 W
雞蛋容量	14
產品尺寸	(H) 240 (W) 201 (D)164.5 mm
淨重	0.8 kg

產品規格及設計如有變更，恕不另行通知。  
中英文版本如有出入，一概以英文版為準。  
本產品使用說明書以 [www.germanpool.com](http://www.germanpool.com) 網上版為最新版本。

此保用只適用於香港及澳門 This warranty is valid only in Hong Kong and Macau

EGG-367-M-26(1)