

MOSQUITO TRAP MTR-100



USER MANUAL

Please read these instructions and warranty information carefully before use and keep them handy for future reference.

**GERMAN
POOL**





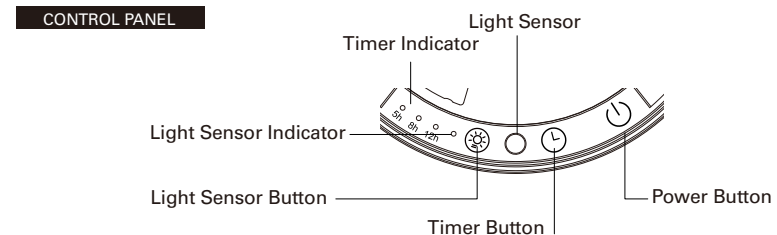
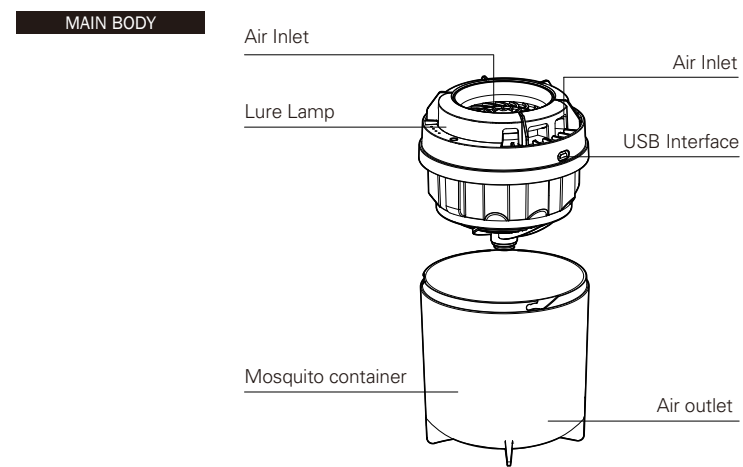

SAFETY INSTRUCTIONS

1. Please check the compatibility between the voltage of the product equipment and the product before using.
2. It is strictly prohibited to disassemble without permission or use the product roughly.
3. It is strictly prohibited to put the product into or near the source of fire to avoid the risk of fire and explosion.
4. When using the product, please try to turn off the light or reduce the light in the mosquito area, avoid other light source interference (such as fluorescent lamp, TV, light outside the window, etc.), avoid direct blowing of strong wind (such as fans, air conditioning, etc.) to the product, the use effect is better in an enclosed space in the absence of man.
5. When the product is working, it is strictly prohibited to stare at the light source of the lamp tube for a long time to avoid the close distance of the light source irradiating the skin.
6. When in use, the product should be placed in a place out of reach of children. It is forbidden to put your fingers or metal objects inside the machine to avoid accidents.
7. If the power line or fan is damaged, please hand it over to specialized person for repair or replacement in order to avoid danger.
8. When not in use for a long time, please unplug the power plug and place it well.

PRODUCT STRUCTURE



Directions For Use

1. Assemble the product, switch on the power and the product enters into Standby Mode.
2. Gently touch POWER button , the mosquito lure lamp will turn on, and the product will start operating.
3. When product is operating, gently touch LIGHT SENSOR button  to activate Light Sensor Mode, and the Light Sensor Indicator will turn on; press LIGHT SENSOR button  again to deactivate Light Sensor, and the Light Sensor Indicator will turn off.
4. When product is operating, gently touch TIMER button to activate Timer Mode. Default timer is 5 hours, and the corresponding light indicator will turn on; touch TIMER button  again to switch to 8 hr and 12 hr respectively. Retouch TIMER button  again to deactivate Timer Mode.
5. When product is operating, gently touch POWER button , lure lamp will turn off, and the product will stop operating.

SUGGESTIONS FOR USE

1. In order to achieve the best effect of mosquito-trapping, please keep product working continuously for more than 12 hours. Do not open the mosquito container frequently during this period, so as to prevent the mosquitoes from escaping.
2. Please close doors and windows when the product is in use. Before going to bed, turn on the product about 3 hours in advance before entering the bedroom.
3. This product is not developed based on the chemical volatile principle, so it cannot take effect immediately like mosquito repellent incense and other products. Please use product with patience.

CLEANING & MAINTENANCE

1. If product is dirty, please wipe with a soft cloth moistened with a small amount of neutral detergent diluted with water, and then dry it with a dry cloth.
2. Do not use volatile oil, thinner alcohol or spray cleaner to clean the product.

SPECIFICATION

Model no.	MTR-100
Voltage	5V
Power	6W
Dimensions	(H)192 (W)141 (D)141mm
Net Weight	0.5kg

Specifications are subject to change without prior notice.
If there is any inconsistency or ambiguity between the English version and the Chinese version, the Chinese version shall prevail.
Refer to www.germanpool.com for the most up-to-date version of the Operating Instructions.





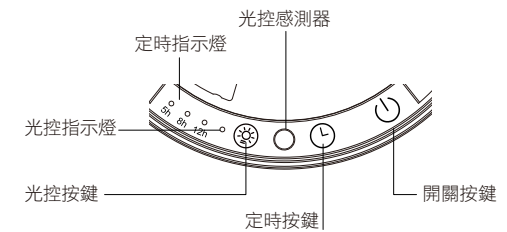
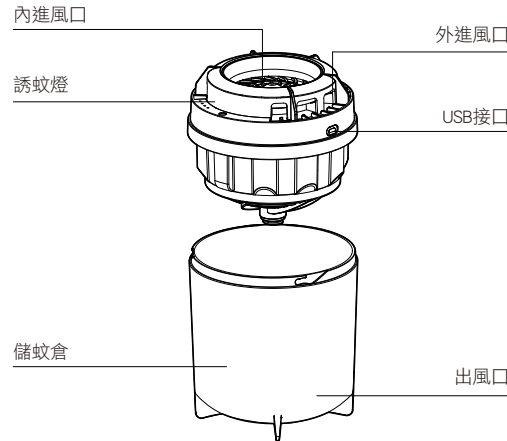

安全注意事項

1. 使用前請先檢查本產品設備的電壓與本產品的兼容性。
2. 嚴禁將產品私自拆裝或粗暴使用。
3. 嚴禁將產品投入或接近火源，以避發生火災及爆炸危險。
4. 使用本產品時盡量關燈或減弱除蚊蟲區域的光線，避免其他光源干擾（如日光燈、電視機、窗外光線等），避免強風（如風扇、空調等）直吹產品，在封閉的空間、無人在場的情況下使用效果更佳。
5. 產品工作時嚴禁長時間注視燈管光源，避免光源近距離照射皮膚。
6. 使用時，本產品應放在兒童無法觸及的地方，請勿將手指或金屬等物體伸進機身內，以免造成意外。
7. 電源線或風機如有損壞，為了避免危險，請交予專業人員維修或更換。
8. 長時間不使用時，請拔下電源插頭，並放置好。

產品結構



使用方法

1. 安裝誘蚊劑後，接通電源，產品進入待機狀態。
2. 輕觸「開關按鈕」，誘蚊燈亮起，產品開始工作。
3. 工作狀態下，輕觸「光控按鈕」，開啟光控功能，光控指示燈亮起；再次輕觸「光控按鈕」，關閉光控功能，光控指示燈熄滅。
4. 工作狀態下，輕觸「定時按鈕」，開啟定時功能，默認時間為5小時，相應指示燈亮起；每輕觸一次「定時按鈕」循環切換：5小時 - 8小時 - 12小時 - 關閉定時功能。
5. 任何工作狀態下，輕觸「開關按鈕」，誘蚊燈熄滅，產品停止工作。

捕蚊建議

1. 為達到最佳捕蚊效果，建議連續使用12小時或以上，期間請勿經常打開儲蚊倉，以免蚊子逃脫。
2. 日常捕蚊時，請關閉好門窗；建議睡前3小時開啟本產品。
3. 本產品非採用化學揮發類原理滅蚊，因此不能像蚊香等產品馬上見效，請耐心使用。

清潔與維護

1. 污漬嚴重時，請用軟布沾少量清水稀釋過的中性清潔劑擦拭，並用乾布擦乾。
2. 擦拭機身等污垢時，請勿使用揮發油、稀釋酒精、噴霧式清潔劑。

技術規格

型號	MTR-100
電壓	5V
功率	6W
尺寸	(H)192 (W)141 (D)141 mm
淨重	0.5kg

- 產品規格及設計如有變更，恕不另行通知。
- 中英文版本如有出入，一概以中文版為準。
- 本產品使用說明書以 www.germanpool.com 網上版為最新版本。

保用條款

此保用提供德國寶產品之機件在正常使用下壹年保用（自購買日起計算）。

- 貴戶須在購機十天內，以下列其中一種方式向本公司登記資料，保用手續方正式生效：

1) 填妥本公司網頁內之保用登記表格
www.germanpool.com/warranty

2) 填妥保用登記卡，郵寄至本公司。



Warranty Terms & Conditions

Under normal operations, the product will guarantee a 1-year full warranty provided by German Pool (effective from the date of purchase).

- * This warranty is not valid until customer registration information is received by our Service Centre within 10 days of purchase via one of the following means:

1) Visit our website and register online:
www.germanpool.com/warranty

2) Complete all the fields on the attached Warranty Card and mail it back to our Customer Service Centre.



另請填妥以下表格並與正本發票一併保存，以便維修時核對資料。用戶提供之所有資料必須正確無誤，否則免費保用將會無效。

Please fill out the form below. This information and the original purchase invoice will be required for any repairs. Warranty will be invalidated if information provided is found to be inaccurate.

型號 Model No.: MTR-100

機身號碼 Serial No.: _____ 發票號碼 Invoice No.: _____

購買商號 Purchased From: _____ 購買日期 Purchase Date: _____

1. 未能出示購買發票正本者，將不獲免費維修服務。
2. 用戶應依照說明書的指示操作。本保用並不包括：
 - 上門安裝、檢驗、維修或更換零件之人工以及一切運輸費用；
 - 因天然與人為意外造成的損壞（包括運輸及其他）；
 - 任何塑膠附件及輔助裝置；
 - 電源接合不當、不依說明書而錯誤或疏忽使用本機所引致之損。
3. 於下列情況下，用戶之保用資格將被取消：
 - 購買發票有任何非認可之更改；
 - 產品被用作商業或工業用途；
 - 產品經非認可之技術人員改裝或加裝任何配件；
 - 機身編號被擅自塗改、破壞或刪除。
4. 總代理有權選擇維修或更換配件。
5. 產品一經被轉讓，其保用即被視作無效。

1. Customer who fails to present original purchase invoice will be disqualified for free warranty.
2. Customer should always follow the operating instructions. This warranty does not apply to:
 - labour costs for on-site installation, check-up, repair, replacement of parts and other transportation costs;
 - damages caused by accidents of any kind (including transport and others);
 - plastic parts and accessories;
 - operating failures resulted from incorrect voltage, improper operations and unauthorized installations or repairs.
3. This warranty is invalid if:
 - purchase invoice is modified by unauthorized party;
 - product is used for any commercial or industrial applications;
 - product is repaired or modified by unauthorized personnel, or unauthorized parts are installed;
 - serial number is modified, damaged or removed from the product.
4. German Pool will, in its discretion, repair or replace any defective part.
5. This warranty will be void if there is any transfer of ownership from the original purchaser.

客戶服務及維修中心

香港

九龍大業街59號
三湘九龍灣貨運中心地下B室

電話：+852 2333 6249

傳真：+852 2356 9798

電郵：repairs@germanpool.com

澳門

澳門俾利喇街145號
寶豐工業大廈3樓

電話：+853 2875 2699

傳真：+853 2875 2661

Customer Service & Repair Centre

Hong Kong

Unit B, G/F, Sunshine Kowloon Bay
Cargo Centre, 59 Tai Yip Street.

電話：+852 2333 6249

Fax：+852 2356 9798

Email：repairs@germanpool.com

Macau

3/F, Edificio Industrial Pou Fung,
145 Rua de Francisco Xavier Pereira,

Macau

Tel：+853 2875 2699

Fax：+853 2875 2661